



BRITISH WHEELCHAIR BASKETBALL

COMPETITION REGULATIONS

SEASON 2023/2024

Version 1.2 Published September 2023

INTRODUCTION TO THE BWB COMPETITION REGULATIONS

These Regulations govern the National League, Women's Premier League, Women's League and Junior League competitions organised by British Wheelchair Basketball (BWB) for the season of 1st September 2023 to 31st August 2024. These Regulations are the only Regulations specified and no other publication is applicable apart from the official IWBF Rules and Interpretations.

In writing these Regulations, we have tried to ensure that the result of any wheelchair basketball match is decided on the court and within the spirit of the game.

Unless specified, these regulations are applicable to National League, Women's Premier League, Women's League and Junior League and National Championship Finals Competitions.

KEY CONTACTS:

BWB – membership@britishwheelchairbasketball.co.uk

BWB Referee Appointments – officials@britishwheelchairbasketball.co.uk

Safeguarding – safeguarding@britishwheelchairbasketball.co.uk

Complaints and Disciplinary – membership@britishwheelchairbasketball.co.uk

SECTION 1. AFFILIATION & REGISTRATION

CLUBS & TEAMS

All Clubs wishing to enter teams into BWB Competitions must affiliate with BWB on the BWB membership portal by **30th June 2023** thereby ensuring eligibility to enter one or more of BWB's National Competitions.

All Clubs must enter their teams for all BWB National Competitions on the BWB membership portal by **30th June 2023**. Entries received after this date are accepted at BWB's discretion.

- 1.1.1** All Clubs or Teams wishing to change their name or merge clubs must submit their proposed name or club proposal to membership@britishwheelchairbasketball.co.uk for approval by 30th June 2023.
- 1.1.2** Any team that competed in the 2022-23 season is permitted to submit a request to the Competitions Working Group to retain or change their divisional status upon the conclusion of the 2022-23 season. All requests must be sent to membership@britishwheelchairbasketball.co.uk by Friday 30th June.
- 1.1.3** If teams do not submit a request to change division from the 2022-23 season, providing the club did not finish in a promotion or relegation spot, the team in question will remain in said division in the 2023-24 season. Overall placings of teams remain at the discretion of BWB and BWB reserves the right to amend league structures in the best interests of the sport.
- 1.1.4** Any Team who has entered a BWB Competition in 2022-23 but chooses not to enter in the 2023-24 season will be treated as a new entrant and placed in the lowest geographical division when entering in future seasons. At their discretion, BWB can place new entrants higher for sporting reasons.
- 1.1.5** Should a team withdraw from a BWB National Competition prior to or during the season, all players will become 'free agents'. Withdrawing Clubs must provide documented evidence of any indebtedness of their members at the time of withdrawal. If no documented evidence is forthcoming, members will be free to re-register with another

team competing in the same competition, as long as they do so before the 1st March 2024 registration deadline. This is subject to penalties and fines relating to team withdrawal, including member specific responsibilities – please see Penalties and Fines relating to Affiliation and Registration (b) & (c)

- 1.1.6** Should a team withdraw from a BWB National Competition after the start of the season, all results involving that team will become void and removed from the league table.
- 1.1.7** All clubs **must** have a designated Welfare Officer at the time of affiliation and for the duration of the 2023-24 season.
- 1.1.8** For all BWB National **Competitions**, the host club is responsible for completing a risk assessment taking into consideration but not limited to; the venue and equipment being used (please reference the National League and Competitions Standard Matrix)

MEMBERS

- 1.1.9** All club members including players, coaches, table officials and team staff must have a current British Wheelchair Basketball membership and hold a role specific licence on the BWB membership portal before participating in any BWB Competitions and Leagues.
- 1.1.10** Each active/current BWB member will be able to access their online licence card via their user profile, this will list the specific licences held by each member.
- 1.1.11** Each participant in any BWB Competition and League must be able to show their virtual licence card to game officials at each fixture; this must include a current licence specific to their role in the game which demonstrates their eligibility to participate in the game. If providing a screenshot of their licence card, the date stamp must be a maximum of 48 hours before the fixture.
- 1.1.12** It is the responsibility of the individual to ensure they are medically fit to play in a BWB Competition.
- 1.1.13** Players become “free agents” at midnight on the day following the end of the National Championship Finals each year and remain so until such time as they register to play for a club in a BWB National Competition for the new season. If no National Championship Finals take place, players are to be “free agents” as of 31st May.
- 1.1.14** A BWB registration is not classed as a contract between club and individual member. Membership registrations cannot be used as evidence should transfer disputes arise during the season.
- 1.1.15** Should a club and player have a legitimate signed contract for the duration of the season or longer, BWB will require a signed copy of said contract within seven days of signature by both parties. Contracts are to be sent into :
membership@britishwheelchairbasketball.co.uk
- 1.1.16** All athletes, support personnel and parents/guardians of minors participating in a BWB National Competition must adhere to the World Anti-Doping Agency (WADA) 2023 prohibited list. If required, participants must apply for a Therapeutic Use Exemption (TUE) prior to competing in BWB National Leagues in the 2023-24 Season.

PENALTIES AND FINES RELATING TO AFFILIATION AND REGISTRATION

- (a) Clubs wishing to enter teams into BWB National Competitions after the 30th June 2023 deadline will be subject to a fine of £50 if entry is accepted by BWB. Teams may be refused entry into Leagues and Competitions at BWB's discretion.
- (b) Clubs who enter a team into a BWB National League or Competition and then withdraw prior to 10th September 2023 will be subject to a fine of £250 per team.
These members will not be allowed to join any other club or compete in a BWB national competition until they have paid their proportion of any outstanding fine.
- (c) Clubs withdrawing a team from a BWB National Competition on or past 10th September 2023 will be subject to a fine of £480. Should this fine not be paid by the club in full by the date set out by BWB at the time of withdrawal.
- (d) Failure of Clubs to have a designated Welfare Officer listed on the Membership Portal at the time of affiliation will result in not being permitted to enter teams into a National Competition.
- (e) Any club or team requesting to change their name after the 30th June deadline, will be subject to an administration fee of £20.

SECTION 2. 2023-2024 FEES

- 1.2.1** Historic debt relating to a club and team will be added to a Club Administrator's individual profile on the BWB Membership Portal before 30th June 2022. All outstanding debt must be cleared prior to 30th June 2023. Failure to do so will result in teams being prevented from entering or being removed from BWB National Competitions and Club Affiliation being revoked.
- 1.2.2** Historic debt relating to an individual will be added to their online profile on the BWB Membership Portal before 30th June 2023. All outstanding debt must be cleared prior to the 30th June 2023. Failure to do so will result in the individual's membership and licence(s) being suspended until the debt has been settled.
- 1.2.3** Any in-season debt accumulated by a club or team must be paid within British Wheelchair Basketball's thirty-day payment terms. Failure to do so will result in each game being forfeited 20-0 with a deduction of one league point.
- 1.2.4** Any in season debt accumulated by an individual must be paid within British Wheelchair Basketball's thirty-day payment terms. Failure to do so will result in the suspension of the individual's licences and therefore ability to participate in BWB Leagues and Competitions until the debt is settled.
- 1.2.5** No individual will be permitted to participate in any official match in a BWB sanctioned Competition until all debt owed to BWB or an affiliated Club has been paid. The claimant must evidence any debt owed to an existing club.
- 1.2.6** All Clubs must affiliate with BWB by 30th June 2023 in order to enter teams into BWB National Competitions. The cost of affiliation is £100. Failure to affiliate will result in teams not being permitted to enter BWB National Competitions.

2.7 All individual teams must pay the entry fee in order to enter a BWB Competition. The following team entry fees become payable to BWB by 30th June 2023:

Competition	Team Fee
National League (inc Premier Division)	£240
Women's League	£240
Women's Premier League	£500
Junior League	£120

1.2.8 Any team withdrawing from a BWB National Competition after the deadline to enter (30th June 2023), will forfeit their entry fee.

1.2.9 The following fees become payable to BWB at the time of registration:

Adult Membership	Junior Membership
£30	£15

1.2.10 Club and member registration fees must be paid at the time of registration. No exceptions to this regulation will be made.

2.11 The following Club roles require a valid, DBS:

- Team Manager
- Coach
- Assistant Coach
- Welfare Officer

A DBS must be carried out at least every three years and be renewed at the start of the season in which they expire i.e. the date the DBS was issued must not be more than three years ago at any point during the season. The DBS must be completed through BWB's chosen application system in line with the procedures for a criminal record check outlined in the criminal records check policy. A DBS qualification will be added to a user's profile once the necessary risk assessment has been carried out. Additional checks may be requested by BWB at any time for membership / registration to be retained. DBS checks are undertaken via the club and payment made directly to the DBS provider. Please note that BWB will have access to view each DBS issued and will keep a record on the BWB membership system of DBS date. This data will be handled in accordance with BWB's Data Privacy Notice.

1.2.12 BWB have the right to postpone, or deem a fixture as forfeited should a team not have a coach with the relevant qualification, BWB licence and a valid DBS for the 2023-24 season.

1.2.13 To coach in a BWB National Competition you must meet the following criteria:

- Must have complete Safeguarding Training within the last three
- Must have completed a wheelchair basketball coaching qualification,
- Must have completed UKAD Coach Clean course within the last two years,
- Hold a valid DBS,
- Be a registered member with BWB,
- Hold a 2023-24 Coach Licence.

2.14 All fees applicable to the current season must be paid at the time of registration as set out in these regulations. This applies equally to team registration and individual registration fees.

SECTION 1.3. INTERNATIONAL CLEARANCE & VISA

INTERNATIONAL CLEARANCE

- 1.3.1** Any player or coach who in the previous season, was licenced in another country is not permitted to participate in a BWB National Competition until clearance has been received in line with the IWBF Regulations, section J3. All players are required to complete the International Clearance Request Form (Appendix 4).
- 1.3.2** A letter of clearance must be obtained from the NOWB where an individual was last licenced before they can be licenced by BWB. This document certifies that the player concerned is free to be licenced by BWB.
- 1.3.3** The letter of clearance may not be limiting or conditional. If applicable, it should mention any sanctions that may be in force against the individual.
Such sanctions may include the unexpired period of suspension from playing, the unpaid amount of a monetary fine, or the unexpired portion of any other sanction.
- 1.3.4** An international transfer is not permitted before a player's 18th birthday in line with IWBF Regulation J3.4.1
- 1.3.5** In line with IWBF Handbook 2021 regulation J3.3.1.4, BWB will charge the pound sterling equivalent (at the time of request) of \$50 (US dollars) for the administration of providing a Letter of Clearance for any previous BWB member joining another NOWB. No Letter of Clearance will be provided without receipt of payment.
- 1.3.6** Should a member wish to transfer to another NOWB, BWB will not be held responsible for paying the administration fee, should it be requested.

PENALTIES AND FINES RELATING TO INTERNATIONAL CLEARANCE

- (a)** Any club playing an individual without obtaining a letter of clearance will receive a £100 fine and 2-league point deduction per game in which the player played, plus forfeiture per game set at 20-0.

VISA'S

Detailed information on visas, including definitions of terminology, can be found in the British Wheelchair Basketball Governing Body Endorsement Policy.

<https://britishwheelchairbasketball.co.uk/rules-regulations/policies/>

- 1.3.7** Teams in National League Premier Division and Women's Premier League, can apply for Governing Body Endorsements for senior players or coaches under the International Sports Person criteria of the British Wheelchair Basketball Governing Body Endorsement Policy.
- 1.3.8** No professional (as classified by Home Office criteria on Professional Sports Persons) non-British sportsperson or coach is permitted to register with BWB unless a valid endorsement from BWB has been received.

PENALTIES AND FINES RELATING TO VISAS

- (a) Any club registering an individual without obtaining a Governing Body Endorsement will receive a £500 fine and 2-league point deduction per game in which the individual was involved, plus forfeiture per game set at 20-0. Any individual found to be in breach of this regulation will have their player licence suspended until a Governing Body Endorsement has been received and notification to the Home Office.

SECTION 1.4. TRANSFERS

1.4.1 Any player seeking to transfer must complete the BWB League Transfer Form (Appendix 2) and return it to BWB along with an administration fee of £15 which will be sent out via invoice at the time of submitting the transfer request. Players will not be permitted to play for their new club until written confirmation by BWB confirming the transfer has been received by the player's new club.

1.4.2 A transfer will be permitted up until 31st January of the current season. No transfer request will be accepted after this date.

1.4.3 A Transfer will not be allowed if any of the following circumstances apply:

- The player is under valid contract to the current club unless that contract is terminated by mutual consent (BWB must see a copy of the valid playing contract).

BWB Membership does not count as a valid contract between club and individual.

- The player has documented indebtedness to the current club, e.g. subscription arrears, kit etc. Teams are advised to ensure that players are made fully aware of their commitments and fees due. Teams will be expected to demonstrate that fees or equipment are owed in writing.

- If the transfer request is within the Women's Premier League.

1.4.4 The releasing club has seven calendar days from dispatch of the League Transfer Form by BWB, to sign and return the completed form to BWB or provide documented evidence of debt. Failure to sign and return the form and/or failure to give proper evidence of refusal of transfer will result in the player being transferred irrespective of the lack of consent.

1.4.5 If a team can provide documented evidence of debt owed by an individual, BWB will block the transfer until such arrears have been settled.

1.4.6 A transfer block can be appealed by an individual in line with BWB's Appeals Protest Policy which can be found in section 13.17.

1.4.7 Only one transfer per person will be permitted per season.

1.4.8 There are no other restrictions on player's eligible to play in the League and Competitions, subject to the time frames laid down in these rules and regulations, providing they have received a licence from BWB and obtained a valid classification under the IWBFB/BWB rules of classification. Any changes to IWBFB's definitions and processes will be reviewed by BWB to establish the impact on the sport in the UK prior to acceptance.

1.4.9 In the event of a transfer, teams are required to continue to adhere to regulation 5.1 in relation to player numbers.

PENALTIES & FINES RELATING TO PLAYER TRANSFERS

- (a) Failure of releasing club to respond to BWB within seven days of transfer request (including providing copies of player contracts or any applicable documentation) – £100 fine.

SECTION 1.5. TEAM ROSTER

- 1.5.1** All teams must have a minimum of seven licenced players by 10th September 2023 (15th October for Women's League). No player can be registered after midnight on 31st January of the current season unless the individual is turning fourteen (thirteen for Junior League) and therefore eligible for the specific competition during this time. All players registering prior to midnight on 31st January must have requested a player licence before midnight on 31st January in order to play in a BWB National Competition or League for the remainder of the season.
- 1.5.2** All players must register with a primary team which they will remain with for the duration of the season, this will be considered their default team.
- 1.5.3** Should a player wish to change their primary team once the season has started, they must authorise this change with BWB.
- 1.5.4** Teams are required to have their seven players (as per regulation 5.1) inscribed on the scoresheet for each fixture during the season.
- 1.5.5** If a player's name is inscribed on the scoresheet without being crossed out due to not being present, BWB will determine that the player in question has participated in the fixture.
- 1.5.6** Each team must be able to play within the team classification points system for the division in which they are playing.
- 1.5.7** A coach, assistant coach and up to a maximum of seven team staff are permitted to sit on the team bench. All people on the team bench must be registered with BWB and hold the relevant licence to perform their intended roles.
- 1.5.8** All registered teams must have a licenced level 2 coach. The level 2 coach must be present at all fixtures where junior members are participating. Where a team does not have a junior involved in the fixture (in any capacity), a licenced Level 1 coach over the age of 18 can lead the team in extenuating circumstances.
- 1.5.9** A licenced Level 2 coach must be present at all team fixtures where a junior player is involved. The fixture cannot go ahead if a team with a junior player does not have a licenced Level 2 coach available for any reason. The fixture will be postponed in accordance with regulation 1.8.15 & 1.8.16. Coaches must hold a valid DBS according to the rules as set out in rule 1.2.11.
- 1.5.10** Players may play up for one other team within their club within the same competition. Each player can play for a maximum of two teams per club, per season. In all cases, players may only 'play-up' if the club has a team in a higher division.
- 1.5.11** Players may not play down for a team in a lower division.
- 1.5.12** Only five players may play up per fixture.
- 1.5.13** The table officials must present the scorebook to each team coach and request they sign next to their name at least ten minutes before tip-off. Each coach is responsible for ensuring all participating players names are listed on the scoresheet. Teams are advised to always check the scoresheet before tap-off.

GENERAL PENALTIES AND FINES RELATING TO TEAM ROSTER

- (a) Teams failing to register a minimum of seven players by 10th September 2023 - £100 fine.
- (b) Failure of team coaches / captains to ensure that all player names, licence numbers and classifications are inscribed on the score sheet will incur a fine of £50 per occasion. It is not the table official's responsibility to ensure this is carried out – coaches should check the sheet before the start of the game.
- (c) Teams who inscribe a non-licenced or ineligible participant on the official scoresheet, will receive a £100 fine per fixture, 2 league point deduction per game in which the participant was involved, plus forfeiture per game set at 20-0.
- (d) Teams who allow non-licenced team staff on their bench during a fixture will be fined £50 per ineligible individual per fixture.
- (e) Failure of a team to provide a Level 2 coach at a fixture (regardless of whether a Junior is involved or not) for two or more occasions during a season will incur a £100 fine per occasion.

PERFORMANCE PROGRAMME

- 1.5.14** There is no restriction on the eligibility of any GB player that a National League, Women's League or Junior League club may register, with the exception of regulations relating to Women's Premier League. For clarity, clubs may sign any number of players currently selected for the GB world-class performance programme. For Women's Premier League please see GB athlete restrictions within the WPL rules and regulations.
- 1.5.15** Clubs are not permitted to register any current GB Performance Coach (defined as a BWB employed GB Performance Coach) to compete or coach within a BWB National Competition.

SECTION 1.6. CLASSIFICATION OF PLAYERS

- 1.6.1** Players in BWB Competitions and International Club competitions must be classified in accordance with the 2014-18 IWFBF Official Player Classification Manual, with the exception of non-eligible players. All non-disabled or non-eligible disability players, (male, female and junior) will be classified at a mandatory 5.0 points. Players are permitted to use any legal strapping. Any changes to IWFBF's definitions and processes will be reviewed by BWB to establish the impact on the sport in the UK prior to acceptance.
- 1.6.2** Further details regarding Classification, including the process of changing a classification can be found in the British Wheelchair Basketball [Eligibility and Classification Policy](#).
- 1.6.3** Upon registration, if medical information is required to confirm a classification, BWB will provide a 5.0 classification.
- 1.6.4** Non-classifiable players are permitted to play in all BWB National competitions and will be classified as 5.0. Only one non-classifiable player per team may be on court at any one time.
- 1.6.5** Any player who does not have a classification on their licence must play as a 5.0. It is the joint responsibility of the individual and the team administrator to ensure licence cards have a classification on. In all cases where a licence does not have a classification on, the BWB Membership department must be contacted to get this rectified.

GENERAL PENALTIES AND FINES RELATING TO CLASSIFICATION OF PLAYERS

- (a) Any player without a classification on their profile that is played in an official fixture as anything other than a 5.0 will result in a £50 fine per fixture, 1 league point deduction per game in which the participant was involved, plus forfeiture per game set at 20-0

CLASSIFICATION OF TEAMS

- 1.6.6** All games in the National League will be played to the following classification on court:

Premier Division	-	14.5 Points
1 st Division	-	14.5 Points
2 nd Division	-	14.5 Points
3 rd Division	-	15.0 Points

- 1.6.7** The maximum number of classification team points allowed on court is capped in all divisions as follows:

Premier Division	-	17 Points
1 st Division	-	17 Points
2 nd Divisions	-	17 Points
3 rd Division	-	17.5 Points

- 1.6.8** The above is the maximum number of points allowable for the five players on court at any time including concessions for women or junior players.

- 1.6.9** Teams who have five players available allowing them to play within the points for their respective division must play to points at all times.

- 1.6.10** Any team arriving at a game that is unable to start the game within the team points classification for their division will forfeit the game 20-0.

- 1.6.11** After starting a game with five players, a team who during the game cannot comply with the classification points system relative to their division because of lack of players due to legitimate injury, player fouling out or disqualification MUST NOT field five players over their respective division points.

They may play with four or less players for the remainder of the game.

- 1.6.12** Any team that fails to play within team points set for their division on four or more occasions will be withdrawn from the league and fined £250. Any report of a team failing to play within team points must be made in line with regulation 13.17.

FEMALE AND JUNIOR PLAYERS IN THE NATIONAL LEAGUE

- 1.6.13** In all divisions in the National League, 1.5 points is added to the team's classification total for each female or junior female player on court (except for 5.0 females), subject to the cap for the division. i.e. if 1 female is on court, the team total increases to 16.0 in the Premier, 1st and 2nd Divisions, 16.5 in the 3rd Division and 17.5 in the 4th Division, up to the maximum team points allowable noted in rule 6.6. For clarification on Trans Athletes, refer to regulations 1.6.17 – 1.6.21.

- 1.6.14** When a 5.0 female goes on court 0.5 points is added to the team's classification. When a 5.0 junior female goes on court 1.0 points is added to the team's classification. For clarification on Trans Athletes, refer to regulations 1.6.17 – 1.6.21.

- 1.6.15** When a male junior player (excluding 5.0 junior players) goes on court, one point is added to the team's classification total, i.e. if one junior is playing, the team total increases to 15.5 in the Premier, 1st and 2nd Divisions, 16 in the 3rd Divisions and 17 in the 4th Division. One point is added to the team classification total for each male junior player on court, subject to the maximum team points allowable noted in rule 1.6.7.
- 1.6.16** No player under the age of fourteen may be licenced to play in the National League. Any player may register and request a licence as soon as they reach the age of fourteen irrespective of where in the season that date falls. No exceptions will be made to this rule.

TRANS ATHLETE REGULATIONS

- 1.6.17** Trans men and trans women are eligible to compete in any male or non-gender specific competition. The team classification total would not increase when the athlete enters the court.
- 1.6.18** Non-binary athletes whose sex at birth is female are eligible to compete in female specific competitions.
- 1.6.19** Non-binary athletes whose sex at birth is female are eligible to compete in non-gendered competitions. The team classification total would increase in line with the regulations for female and junior players specific to that competition.
- 1.6.20** Non-binary athletes whose sex at birth is male are eligible to compete in male specific competitions.
- 1.6.21** Non-binary athletes whose sex at birth is male are eligible to compete in non-gendered competitions. The team classification total would not increase when the athlete enters the court.

SECTION 1.7. NATIONAL LEAGUE FORMAT

- 1.7.1** Unless stated otherwise, teams will play each other once at home and once away in all divisions.
- 1.7.2** In all League games, two league points will be awarded for a win and one league point will be awarded for a defeat. Where league fixtures are 'void' due to adverse weather or Government restrictions, one point will be added to each team's league points total.
- 1.7.3** Clubs are permitted to have a maximum of two teams in the same geographical Division. The exception to this is the Premier Division which cannot have more than one team per club.
- 1.7.4** BWB reserves the right to adjust the League structure in the best interests of the sport.

FEMALE AND JUNIOR PLAYERS IN THE NATIONAL LEAGUE

1.7.5 For all Divisions, if two or more teams have the same win-loss record of all games in the group, the game(s) between these two or more teams shall decide on the final league position. If the two or more teams have the same win-loss record of the games between them, further criteria will be applied in the following order:

- (a)** Higher game points difference of the games between them.
- (b)** Higher number of game points scored in the games between them.
- (c)** Higher game points difference of all games in the group.
- (d)** Higher number of game points scored in all games in the group.
- (e)** If still tied before all games have been played in the group, tied teams shall share the same ranking. If these criteria still cannot decide at the end of the group phase, a draw shall decide on the final classification.

PREMIER DIVISION

- (a)** The Premier Division will be run on a national basis and will comprise of an optimum number of eight teams.
- (b)** Clubs are restricted to only one team in the Premier Division.
- (c)** Teams will play each other twice, once at home and once away. The results from these games will determine the regular season Premier Division Champions.
- (d)** The teams finishing in the bottom two positions at the end of the season will be relegated.
- (e)** In certain circumstances, BWB may retain a team or teams due to be relegated in this division if a number of teams from Division 1 are prohibited from accepting promotion due to Division 1 regulation (b) or for any other reason related to maintaining eight.
- (f)** Any team within the BWB National League is eligible to enter the 2023-24 EuroCup Competition.
- (g)** At the conclusion of all league games, the teams finishing in the top four positions in the Premier Division will qualify for the 2023-24 National Championship Finals.

DIVISION 1

- (a)** Division 1 will comprise of up to three divisions, geographically split, with a maximum of eight teams in each. BWB will determine the number of divisions based on entries after 30th June deadline.
- (b)** In the case of there being two divisions, the top two teams from each division will advance to the National Championship Finals and play end of season play-offs. The two finalists will be promoted to the Premier Division for the 2024-25 season.
- (c)** In the case of there being three divisions, the division winners plus one wildcard team will advance to the National Championship Finals. The wildcard team will be determined by comparing all second placed teams within Division 1 and comparing their records against the team finishing first in their respective division. If the two or more teams have the same

win-loss record of the games between them, the criteria used in regulation 1.7.5 will be used to determine the wildcard. The two finalists at the National Championship Finals will be promoted to the Premier Division for the 2024-25 season.

- (d) The seedings will be based on win percentage against second place in their division. If the two or more teams have the same win-loss record of the games between them, the criteria used in regulation 1.7.5 will be used to determine the seeding. The wildcard team will automatically be seeded 4th.

The semi-final fixtures will be:

1st v 4th
2nd v 3rd

- (e) Where a team is unable to be promoted due to the club already having a team in the Premier Division, the winner of the 3rd v 4th Playoff at the National Championship Finals shall be promoted.
- (f) The team finishing in the bottom position in each regional division at the end of the season will be relegated.
- (g) BWB may be forced to retain or promote a team in this division in the best interests of the league. BWB's decision is final.

DIVISION 2

- (a) Division 2 will comprise of up to three divisions, geographically split, with a maximum of eight teams in each. BWB will determine the number of divisions based on entries after 30th June deadline.
- (b) In the case of there being two divisions, the top two teams from each division will advance to the National Championship Finals and play end of season play-offs. The two finalists will be promoted to Division 1 for the 2024-25 season.
- (c) In the case of there being three divisions, the division winners plus one wildcard team will advance to the National Championship Finals. The wildcard team will be determined by comparing all second placed teams within Division 2 and comparing their records against the team finishing first in their respective division. If the two or more teams have the same win-loss record of the games between them, the criteria used in regulation 1.7.5 will be used to determine the wildcard. The two finalists at the National Championship Finals will be promoted to Division 1 for the 2024-25 season.
- (d) The seedings will be based on win percentage against second place in their division. If the two or more teams have the same win-loss record of the games between them, the criteria used in regulation 1.7.5 will be used to determine the seeding. The wildcard team will automatically be seeded 4th.

The semi-final fixtures will be:

1st v 4th
2nd v 3rd

- (e) In the case of there being three Divisions in Division 1, the winner of the 3rd v 4th Playoff will also be promoted due to regulation Division 1 (f).

- (f) The teams finishing in the bottom two positions in each regional division at the end of the season will be relegated.
- (g) BWB may be forced to retain or promote a team in this division in the best interests of the league. BWB's decision is final.

DIVISION 3

- (a) Division 3 will comprise of up to four divisions split geographically. BWB will determine the number of divisions based on entries after 30th June deadline.
- (b) At the conclusion of all league games, the team finishing in first position in each regional division will qualify for the 2023-24 National Championship Finals.
- (c) In the case of there being three divisions, the division winners plus one wildcard team will advance to the National Championship Finals. The wildcard team will be determined by comparing all second placed teams within Division 3 and comparing their records against the team finishing first in their respective division. If the two or more teams have the same win-loss record of the games between them, the criteria used in regulation 1.7.5 will be used to determine the wildcard. All four teams will be promoted to Division 2 for the 2024-25 season.
- (d) The seedings will be based on win percentage against second place in their division. If the two or more teams have the same win-loss record of the games between them, the criteria used in regulation 1.7.5 will be used to determine the seeding. The wildcard team will automatically be seeded 4th.
The semi-final fixtures will be:
1st v 4th
2nd v 3rd
- (e) BWB may be forced to retain or promote a team in this division in the best interests of the league. BWB's decision is final.
- (f) BWB may change the structure of Division 3 and the qualification process for the National Championship Finals dependant on the number of entries.

National Championship Finals – 18th & 19th May 2024, University of Essex (CO4 3SQ)

- 1.7.6** All teams qualifying for the National Championships must send their Logo and Team Sheet for the National Championship Finals to membership@britishwheelchairbasketball.co.uk by Sunday 13th May 2024.
- 1.7.7** Should the National Championship Finals be cancelled due to adverse weather or Government restrictions, every effort will be made to find an alternative date & venue. If this is not possible, all fixtures will be void.

SECTION 1.8. ARRANGEMENT OF NATIONAL LEAGUE & NATIONAL LEAGUE FIXTURES

- 1.8.1** BWB will create the National League structure and provide a provisional fixture list for clubs to organise their fixtures for the coming season.

1.8.2 All clubs must return their confirmed fixtures to: membership@britishwheelchairbasketball.co.uk including their home fixtures dates, venue and tap-times by Sunday 27th August 2022. .

Failure to provide fixtures by this date may result in officials not being appointed, and the game being forfeit.

1.8.3 Clubs with more than one team in the same geographical division must play each other twice before either team plays any other team from another club.

1.8.4 National League fixtures must be played between **Saturday 16th September 2023 and Sunday 21st April 2024.**

1.8.5 The weekend of 27th / 28th April and 4th and 5th May 2024 may be used for rearranged fixtures **during the season** if no other alternative dates are workable. Prior approval from BWB must be sought before agreeing to use this weekend.

1.8.6 National League games can be played on the weekend of Women's Premier League and Women's League or on nominated Junior League dates providing there are no clashes with female and Junior Players. Any teams with registered Women's Premier League, Women's League or Junior league must prioritise players participating within these leagues over national league. In the case where players are registered for teams in the aforementioned leagues, fixtures must be rescheduled at a time that allows females and juniors to take part. Female or junior players not licenced for Women's Premier League, Women's League or Junior League are entitled to play national league games regardless of if there is a clash.

1.8.7 It is the expectation that all clubs work together to reduce the fixture congestion wherever possible. Club contacts will receive all fixtures at the same time to ensure clashes are minimised and any changes made to the draft National League fixtures are done collaboratively between teams with the athletes in mind.

1.8.8 National League games are only permitted to be played on the weekends of a Home Nation Programme (including Commonwealth Games preparation and Regional Academies) if the teams involved do not have any athletes participating in a Home Nations Programme. The dates of the Home Nations Programme are:

- 21st & 22nd October 2023
- 16th & 17th December 2023
- 13th & 14th April 2024
- 1st & 2nd June 2024

1.8.9 Clubs must contact their opponent no later than seven days in advance of a fixture to confirm the venue and tap time. Clubs do not need to notify referees but must copy in BWB Membership and the BWB Referee Appointments Officer who will check details corresponding to those listed on the officials' appointment software.

1.8.10 All matches must be played on the date, the time and at the venue specified on the BWB website, and not any other publication. If there is an error on the website, then teams are responsible for letting membership@britishwheelchairbasketball.co.uk know as soon as possible who will update the details on the BWB website.

- 1.8.11** Fixtures may be re-arranged providing that the BWB Fixture Change document has been returned (Appendix 3). It is the responsibility of the requesting club to return the BWB fixture change document via email to BWB, the opposition and the Referee Appointments Officer at least twenty-one days prior to the original fixture date. Requests received with less than twenty-one days' notice will only be considered in exceptional circumstances. An administration fee of £15 will be required in order to confirm any fixture change where there is less than twenty-one days' notice.
- 1.8.12** Priority of fixtures: This lists the orders of priority fixtures have over one another. GB Internationals; European Club Competitions; Women's Premier League, Women's League, Junior League, National League Fixtures, Approved BWB events; All other club games and tournaments both home and abroad.
- 1.8.13** The home team is responsible for the venue and equipment. Equipment failure and start time changes will not normally be considered to be outside the control of the team.
- 1.8.14** Failure to provide a home venue for a play-off game on the dates prescribed above will result in the designated home team forfeiting the fixture 20-0 and fine of £100.

MATCH POSTPONEMENT

- 1.8.15** Where a team is responsible for the postponement of a match (up to twenty-four hours prior to the tap-off time) due to the venue owners cancelling the court booking, the match must be rescheduled (not necessarily played) within fourteen days of the postponement. Confirmation from the venue that the original booking was cancelled by the venue must be provided. Failure to provide confirmation from the venue will result in the matter being considered by BWB who is entitled to award the match to the opposition following investigation.
- 1.8.16** Where a team is responsible for a fixture being postponed for any reason other than adverse weather or Government restrictions, the **home** team must provide suitable dates for a re-arrangement within fourteen days. In the event that after four weeks since the original match date, the two clubs cannot reach an agreement as to when the rescheduled match should take place, the result will be recorded as 20-0 in favour of non-offending team. The offending team will have 1 league point deducted.

**BWB want the outcome of fixtures to be determined on the Field of Play where possible.*

- 1.8.17** In the event that a fixture is postponed:
- The travelling expenses (if applicable) of all match officials will be paid by the home team
 - The home team shall be liable for all costs associated including the cost of the court hire.
 - The responsibility for notifying BWB and match officials of a postponement lies with the home team.
 - BWB may ask for confirmation or evidence of the travel that was intended, type of vehicle due to be used and details of the breakdown, including any roadside assistance.
 - All costs associated with the rearrangement of the fixture are to be paid for by the offending team.
- 1.8.18** Teams must follow all current Government Guidelines for COVID-19 published at the time of competition. Match postponement related to COVID-19 will refer to regulation 1.8.14-1.8.15 Match Postponement.

ADVERSE WEATHER

1.8.19 In the event of adverse weather, teams should make every effort to play their fixtures whilst taking responsibility for their own safety. If either team feels they are unable to complete the fixture they must ensure they have professional and independent evidence (e.g. Weather, Public transport company, Police, Motoring organisation, Sports Hall) indicating travel conditions and advice or hall closure notice. Teams are expected to call and email the opposition, officials@britishwheelchairbasketball.co.uk and membership@britishwheelchairbasketball.co.uk as soon as possible.

1.8.20 In the event that a fixture is postponed due to severe weather conditions:

- The travelling expenses (if applicable) of all match officials will be paid by the home team where it has not been possible to cancel the fixture prior to the officials starting their journey.
- The home team shall be liable for all costs associated including the cost of the court hire.

1.8.21 Within fourteen days of the postponement of a match, the postponing team shall provide suitable dates for a re-arrangement within the current season fixture window. In the event that after four weeks of the original match date, the two clubs cannot reach an agreement as to when the rescheduled match should take place, the match will be void and no points awarded to either team.

MATCH ABANDONMENT

1.8.22 Where a Match is abandoned, BWB shall reach a decision on the result and outcome of the match based on the circumstances surrounding each case. Only participants listed on the original scoresheet are eligible to play in any replay. If a Club is unable to field a full team in the replay (by way of example only, due to injury or illness) then BWB shall (in its sole discretion) determine whether such replay should be rescheduled for an alternative date or be forfeited by the club unable to field a full team.

FORFEITS

1.8.23 A team shall forfeit the match if fifteen minutes after the schedule tap-off time, the team is not present on court and / or prevents the match being played due to its actions.

1.8.24 If during a game where U18's are involved, a coach is disqualified and there is no other registered and licenced Level 2 coach present to take over from the disqualified coach, the fixture must be forfeited by the offending team 20-0 and the game abandoned.

1.8.25 When a scheduled match is forfeited, a 1-league point deduction will be applied to the offending team and a fine will be imposed as follows:

Competition	1st Offence Fine	Subsequent Offence Fines
Women's Premier League	£200*	£500 & review of League position
National League Premier Division	£200	£500 & review of League position
National League Division 1-3	£100	£200 & review of league position
National Championship Finals	£500	£500 & review of League position
Women's League	£100	£200 & review of league position
Junior League	£100	£200 & review of league position

* For games due to be played away at Knights (Northern Ireland) this fine will be up to £1,000.

GENERAL PENALTIES AND FINES RELATING TO FIXTURES ARE AS FOLLOWS:

- (a)** Any team not confirming fixtures by 27th August 2023 will be fined £100.
- (b)** A club who plays a licenced Women's Premier League or Women's League player in a league fixture on a designated Women's Premier League or Women's League weekend without prior approval - £100 fine 2-point deduction per game in which the player played, plus forfeiture of game 20-0, unless the game is won by opponent by more than 20 points, in which case, the game score will stand.
- (c)** A club who plays a licenced Junior League player in a National League fixture on a designated Junior League weekend without prior approval - £100 fine 2-point deduction per game in which the player played, plus forfeiture of game 20-0, unless the game is won by the opponent by more than 20 points, in which case, the game score will stand.
- (d)** Failure to provide table equipment will result in a fine of £100 per item per game.
- (e)** Failure of home team to provide official score book at game will result in a £100 fine and forfeiture of game if unable to be played.
- (f)** Teams who fail to complete all their league games in a season, or who have been excluded from the league the previous season, will only be permitted to enter the league the following season on payment of a £100 surety fee. This fee will be held by BWB until the completion of the season. If the club/team completes all its fixtures in this season, the surety fee will be returned in full.
- (g)** A Club that places a fixture on weekends designated on Home Nation Programme weekends without prior approval from BWB will result in a fine of £100

SECTION 1.9. MATCH DAY MANAGEMENT

- 1.9.1** Team Contacts / Administrators must submit their team list on the BWB membership portal by tap-off.
- 1.9.2** Playing teams must show / provide the scorer, no later than 20 minutes prior to tip-off, at all games their electronic Licence Cards.
- 1.9.3** The home team is responsible for appointing appropriately licenced and qualified table officials. It is the responsibility of referees and table officials to ensure that the scoresheet is completed in full including correctly spelt names, licence numbers, classifications and the lining out of those who did not attend the fixture.
- 1.9.4** It is the responsibility of the team coach to ensure that all participant licences are available on match day, and to verify their own team information as presented on the scoresheet. Their agreement of this is their signing of the scoresheet.
- 1.9.5** Licence cards can be printed via the team hub on the Membership Portal (web version only) or shown / screenshotted using the BWB app. All licence cards must be date stamped with the date before or date of the fixture when being shown to Officials.

GENERAL PENALTIES AND FINES RELATING TO MATCH DAY MANAGEMENT ARE AS FOLLOWS:

- (a)** Failure to submit individual fixture team list on BWB membership portal by tap-off will result in a £25 fine per occurrence.
- (b)** Failure by a team to show valid licence cards for all participants in line with Regulation 9.5 on match day will result in the fixture being postponed in line with regulations 8.14 & 8.15.

SECTION 1.10. RESULTS

- 1.10.1** Match results must be entered directly onto the BWB match card by the Home Team up until midnight of the day of the fixture.
- 1.10.2** Individual player points must be entered directly onto the BWB match card by the Home Team by midnight on the Sunday of the weekend that the fixture took place.
- 1.10.3** If a match is forfeited, the Home Team must enter the result as a walkover on the Membership Portal.
- 1.10.4** A visible and clear photograph of the scoresheet must be uploaded onto the membership portal before midnight on the day of the fixture. If an official has made any notes on the back of the scoresheet, both sides must be photographed and emailed to membership@britishwheelchairbasketball.co.uk

GENERAL PENALTIES AND FINES RELATING TO RESULTS:

- (a)** Failure to submit the result and points scored into the BWB app match card will result in a £25 fine per occurrence.
- (b)** Failure to upload the scoresheet to the BWB app - £50 fine.

SECTION 1.11. UNIFORM AND EQUIPMENT

- 1.11.1** In all official BWB National Competitions players must wear matching kit. This comprises of matching coloured vests of a single dominant colour with a legal playing number (numbers 0, 00 and 1 to 99).
- 1.11.2** The Home team must wear 'light' uniform (e.g. white, yellow or pale blue) unless otherwise agreed with opposition & officials. The away team must wear dark or coloured uniforms.
- 1.11.3** All players must wear tracksuit bottoms, trousers or shorts of a uniform colour. Players wearing jeans will not be allowed to play.
- 1.11.4** Undershirts may be worn provided they are the same dominant colour as the playing strip.
- 1.11.5** Compression sleeves are permitted providing they are the same dominant colour as the playing shirt or black, or white but all players on the team must wear the same colour.
- 1.11.6** No jewellery is to be worn at any time during fixtures, this includes the warm-up. The taping over of jewellery is not permitted. Any players found to be wearing jewellery will be asked to remove it. Failure to do so will result in the player being removed from court. This is at the referee's discretion.
- 1.11.7** All appointed Officials must wear the most up to date BWB Officials kit for all BWB appointed fixtures.
- 1.11.8** Home clubs must provide the following equipment for all games;
- An official score book. In the Premier Division, the scorebook must be the current international version.
 - A visible scoreboard comprising of a countdown resettable game timing device, team score, the number of time outs taken and team fouls committed as a minimum. The scoreboard must be of a size easily visible to both coaches, preferably on opposite side to the team bench areas.
 - 24 second device and displays (Obligatory in Premier Division and recommended for Division 1). Optional in all other divisions.
 - Player foul markers numbered one to five.
 - Team foul markers.
 - Alternate possession arrow.
 - At least two match balls in good condition for the referees to choose from.
- 1.11.9** The **Molten B7G4500** composite basketball is the official game ball in all National League divisions and must be used. No other manufacturer's ball is permitted to be used.
- 1.11.10** Guidance and regulations regarding uniform and wheelchairs can be found in Appendix 7 and 8 respectively.

GENERAL PENALTIES AND FINES RELATING TO UNIFORM AND EQUIPMENT:

- (a)** Failure of home team to provide the BWB designated game ball for the competition - £100 fine per game.
- (b)** Players wearing illegal number or kit will incur a £10 fine per player per occasion.

SECTION 1.12. OFFICIALS

- 1.12.1** Where possible, two qualified referees will be appointed by BWB for all official fixtures.
- 1.12.2** The appointment of two referees may not always be possible depending on availability
- 1.12.3** The fixture must go ahead even if there is only one available referee on the day of the game. It is the requirement for the referee to contact: officials@britishwheelchairbasketball.co.uk and the home team to confirm their unavailability for the fixture.
- 1.12.4** Where the fixture is already scheduled as a single crew appointment, and the remaining referee becomes unavailable on the day, the fixture will be postponed. In this instance, the criteria set out in regulation 8.14 & 8.15 are to be followed. BWB can not be held responsible for any costs incurred in this situation.
- 1.12.5** There is no requirement for clubs to contact referees prior to each fixture. If referees fail to turn up at a game, please contact the BWB Referee Appointments Officer. If you're unable to contact the BWB Referee Appointments Officer from the venue, please cancel the game and make contact by telephone or email as soon as possible.
- 1.12.6** The home team is responsible for paying the game fee and full travel costs of each referee on the day of the game. When paying by bank transfer, the fee must be received by the referee within three working days of the game. When two referees travel in the same vehicle to a game, only the driver can claim travel expenses. If officials incur car parking / toll fees, these must be paid in addition to the travel costs.
- 1.12.7** No registered referee will be appointed to referee fixtures due to a conflict of interest, without expressed consent from both teams, this includes but not an exhaustive list family connection to club members, within that club, affiliation/connection to team competing within same division. coaching players.
- 1.12.8** The home team in all BWB National Competitions is required to provide registered and appropriately licenced Table Officials. Competition requirements are listed in Appendix 9.
- 1.12.9** All statisticians must hold a BWB 2022/23 Statisticians licence.
- 1.12.10** Any players attending a fixture without a classification on their licence card must be recorded on the scoresheet as a 5.0.
- 1.12.11** All Officials are expected to wear the most up to date BWB kit. Kit can be purchased from the online shop: [British Wheelchair Basketball - Workforce | Kukri Sports |](#)
The password for ordering kit is BWBworkforce
- 1.12.12** Officials appointed for BWB events and any broadcast League Games must wear most up to date BWB uniform for all games.

FEES

1.12.13 Referees - Rates for 2023/24 season:

Competition	Team Fee
Premier Division	£45
Division 1	£40
Division 2	£30
Division 3	£25
Junior League	£80 per day plus travel expenses at £0.35 per mile up to 100 miles. Remaining expenses claimed from BWB.

1.12.14 Travel expenses are paid at £0.35 per mile for all miles of actual travel up to a maximum of 160 miles. Any remaining expenses can be claimed from BWB by the referee.

When only one referee officiates at a game, they additionally receive 50% of the second referee's fee.

1.12.15 Table Officials – Recommended Rates for 2023/24 season:

Competition	Rate
Level 1 table official	£10 / game
Level 2 table official	£15 / game
Level 3 table official	£20 / game
Approved 24 second operator	£20 game (if not included in above)

GENERAL PENALTIES AND FINES RELATING TO OFFICIALS:

- (a) £100 fine if officials are not paid on the day of the game or within 3 working days if bank transfer payment is used.
- (b) Failure to provide BWB licenced Table Officials as per Appendix 9 at a game will incur a fine of £50 per official per game.
- (c) Failure to provide a statistician at a Premier Division home game will incur a fine of £200.
- (d) Failure to wear most current up to date uniform at BWB events may result in removal of appointments

SECTION 1.13. DISCIPLINE, APPROACHES, DISQUALIFYING FOULS, PROTESTS AND APPEALS

All regulations in the following section relates to occurrences that take place within or around the field of play and within the realms of official BWB fixtures. For any other disciplinary issues or complaints, please refer to the Disciplinary Policy which can be found here:

<https://britishwheelchairbasketball.co.uk/rules-regulations/policies/>

DISCIPLINARY ACTION

1.13.1 BWB is empowered to discipline a player, coach, club, team, team follower or official whose actions are considered to bring the game or sport into disrepute. BWB is authorised within its absolute discretion to suspend or fine a coach, player, club, team, team follower or official in circumstances where it considers it appropriate. These provisions apply to all BWB affiliated competitions.

1.13.2 Where an incident has occurred within a fixture, reports must be filed in writing within 14 days in order for BWB to investigate.

1.13.3 Club Officials and BWB licenced Officials including Referees must respond, within seven days to legitimate requests for information made by BWB when conducting preliminary investigations.

Failure to do so will result in a fine of £100 and will be taken into consideration when complaints and appeals are being considered.

1.13.4 BWB shall be entitled in its absolute discretion to impose penalties for the following – please note that BWB retains the right to impose a time specific ban (with relevant licence(s) suspension) rather than match should the circumstances necessitate the change:

Incident	Suspension	Fine	Data Retention Period
1. Repeated instances of violent behaviour or physical violence <i>(includes repeated incidents of pushing, hitting, assaulting players/officials/coaches/spectators)</i>	10 matches - Unlimited	£250 - £1,000	5 years or length of ban + 1 year
2. Premeditated violent behaviour <i>(includes planning to push, hit, assault players/officials/coaches/spectators as well as threatening with violence)</i>	10 matches - Unlimited	£250 - £1,000	5 years or length of ban + 1 year
3. Isolated instance of violent behaviour or physical violence <i>(includes a single incident of pushing, hitting, assaulting players/officials/coaches/spectators)</i>	6 – 8 matches	£250	2 years
4. Threatening or aggressive behaviour <i>(includes intimidation and threatening to physically injure someone)</i>	4 - 6 matches	£50 - £150	2 years
5. Aggressive verbal abuse <i>(includes discriminatory abuse, continuous abuse, repeatedly shouting at a player/official/coach/spectator)</i>	2 - 10 matches	£50 - £250	2 years
6. Obscene and foul language <i>(includes insults and swearing and the use of sledging directed at any player/official/coach/spectator)</i>	2 – 4 matches	£50 - £150	2 years

7. Conduct likely to bring the game into disrepute/breach of code of conduct (includes any conduct that can be considered against the spirit of the game by a player/coach/official undertaken within the sport's environment*)	2 – 10 matches	£50 - £500	2 years
8. Corruption/match-fixing/betting (includes conspiring to commit corruption, attempting to influence players/coaches/officials to affect the outcome of a match outside of playing parameters)	10 matches – unlimited	£500 - £1,000	5 years or length of ban + 1 year
9. Dangerous play likely to cause injury (includes any action during play which endangers the health and well-being of another player/coach/official)	1 – 4 matches	£50 - £150	2 years

1.13.5 Any sanction imposed will not be considered served, until the fine has also been settled. The suspension will continue to be in place until the debt is resolved.

1.13.6 In the event of BWB considering the alleged behaviour as above, then any party may be required to attend or provide information to a disciplinary panel hearing in which the penalties can be applied.

1.13.7 BWB recognises the impact social media platforms have on the modern society and promotes the use of all platforms for the promotion of the sport. In line with these regulations, any registered member found to bring the game into disrepute through the use of social media channels (including slander of BWB in it's entirety or any member of staff) will be penalised in line with regulation 13.3. Point 7.

1.13.8 There shall be a right of appeal to any decision made by BWB. This process is outlined in regulation 13.18.

ILLEGAL APPROACHES

1.13.9 No club shall approach a player with a view to persuading them to leave another club once the 11th September 2022 deadline has passed. The only exception to this regulation is for any player applying to a university for educational purposes and associated team for the following season.

Only once an individual is classed as a free agent as per Regulation 1.15 can a club contact a non-club member

1.13.10 Any player moving location due to committing to a university away from home may contact clubs in the area of their expected university at any time during the season.

1.13.11 This restriction applies to all club members, or other persons acting on behalf of or purporting to act on behalf of a club. Infringements of this regulation will be referred to BWB and considered as bringing the game into disrepute and will be dealt with as misconduct.

1.13.12 BWB has the right to seek evidence and testimony from all parties involved, and a record of all complaints made shall be kept and reviewed.

1.13.13 Where it is felt there is a case to answer, with relevant evidence, it shall be referred to BWB for investigation and resolution. Sanctions may include reprimand, fine or suspension. No transfer will be approved until the conclusion of the disciplinary process.

1.13.14 No approach should be made directly to Under 18's unless they are committing to a university the following season. All approaches must be made through the parents.

DISQUALIFYING FOULS

1.13.15 Any licenced player, coach, or team staff member disqualified from a game because of a disqualifying foul, will receive disqualification points and a fine in line with the offence listed in the table on the previous page. The fine will be issued fourteen days after the date of issue, permitting any appeal to be lodged within seven days of the disqualification.

1.13.16 Any player, coach, or team staff member who is licenced for a club with multiple teams must serve the suspension for the team they were representing at the time of receiving the disqualification. This applies to all BWB Competitions.

1.13.17 The player, coach or team staff member who is suspended from a fixture due to receiving a sanction is not permitted to take part in any of the other club games until the full suspension has been served.

1.13.18 Any unserved ban from a previous season shall be carried forward to the following season.

1.13.19 All reports from game officials regarding disqualifying fouls will be reported to BWB who has the jurisdiction to impose additional penalties if considered necessary in adherence with regulation 13.3.

PROTESTS

1.13.20 If a team believes its interests have been adversely affected by a decision of a game official, or any event whatsoever that took place during a game, it must proceed in the following manner;

(a) At the moment the incident takes place, the next time the ball becomes dead and the game clock is stopped, the captain of the team shall make their observations to the referee in a calm and courteous manner.

(b) The referee may explain the decision, or if necessary may examine the score sheet and check the score and playing time. If the interruption exceeds 30 seconds, it shall be charged as a time out to the team in question, unless the referee decides otherwise.

1.13.21 In all official fixtures, at the end of a game if a team considers that it has suffered unreasonable harm by virtue of any occurrence concerned with the game, with the exception of decisions made by the game officials, the captain of the team may sign the score sheet "under protest". This must be done within ten minutes of the end of the game. The referee shall ensure that they do not close the score sheet by signing it until the ten-minute period has elapsed. All game officials, and table officials, should remain at the disposal of the referee until they have signed the score sheet. If a team signs "under protest" it must adopt the following procedure to ensure that the protest is valid.

- (a) A written report must be received by BWB within seven days of the game and include the fee of £100 made payable to British Wheelchair Basketball (refundable if protest is upheld).
- (b) All officials must send a report to BWB within seven days of the game. The written reports should be factual. The matter will initially be judged by BWB who may seek advice from any person that may be able to assist.

APPEALS

13.20 Any decision made by BWB can be appealed. All appeals must be made membership@britishwheelchairbasketball.co.uk within seven days of notification of the decision. The appeal fee of £150 (returnable if upheld) must be paid to British Wheelchair Basketball at the time of submission. The appeal must be written and will be judged by the independent panel, (minimum of three persons), considered qualified to adjudicate who will be appointed by the Chief Executive Officer.

The result is final and shall be notified to the appellant within seven days by BWB.

SECTION 1.14. SPORTS BETTING

- 1.14.1** No player, club/team representative or official shall place or attempt to place a bet on any BWB sanctioned fixture.
- 1.14.2** No player, club/team representative or official shall receive, seek or attempt to receive or seek a bribe to fix or contrive a result or the progress of a match or other event or competition in which they or their club participates.
- 1.14.3** A player, club/team representative or official shall report any approach or other activity which contravenes, or which may contravene, the sport's rules on betting to BWB and co-operate with any investigation and/or request for information including the provision of documentation (e.g. telephone/betting records to officials engaged in the investigation of suspected integrity issues in the sport in relation to betting)
- 1.14.4** Any breach of this regulation will be dealt with in accordance with regulation 13.3.

SECTION 1.15. BWB BROADCAST FIXTURES

1.15.1 Due to broadcasting rights, no team / title sponsors will be accepted onto any televised graphic or BWB press material. For example, should a team be called 'Grantham and Co Liverpool Docklands' the team would be called 'Liverpool Docklands' on all televised graphics and BWB press material. No exception to this rule will be made.

SECTION 1.16. FACILITIES

- 1.16.1** Each club entering a team/ s into a BWB National League or Competition must have a suitable venue listed as their 'home' venue for the duration of the season. The facility must be of a quality deemed by BWB to be suitable for the level of the competition. This must be in line with the BWB Facilities Standards Matrix (Appendix 5).
- 1.16.2** All venues used for a National BWB Leagues and Competitions must have FIBA Court Markings.

- 1.16.3** Upon arrival at the venue, the match referees have the power to deem the fixture 'forfeited' by the home team if the court being used does not meet the required standards set out in the BWB Regulations or League Standards Matrix (Appendix 5). If the court does not meet the required standard and the fixture is forfeited, sanctions found in regulation 8.24 will be imposed.
- 1.16.4** Officials can judge facilities not meeting reasonable health and safety standards and where applicable deem the fixture forfeited by the Home team. In instances where this is the case, the referee / s must provide BWB with a report stating their reasons for the venue being classed as unsafe. BWB will follow up with the Home team requesting improvements and a change of venue ahead of their next home fixture. If a team does forfeit due to facilities not being deemed safe, sanctions found in regulation 8.24 will be imposed.
- 1.16.5** All clubs are required to complete a 'home' venue Risk Assessments prior to hosting their first home fixture of the season, this risk assessment must also be revised should there be any changes to venue which might impact the findings and recommendations of the original assessment. In addition, a risk assessment must also be completed for all venues used by a team during a season (including training venues). A Risk Assessment template for use can be found in Appendix 6.

GENERAL PENALTIES AND FINES RELATING TO FACILITIES:

- (a)** Any club confirmed to be hosting fixtures on any court not using FIBA Court Markings will be fined £250 and required to find an alternative venue for all remaining fixtures.

SECTION 1.17. SPECTATORS

- 1.17.1** All spectators in attendance at a BWB sanctioned competition or event must adhere to BWB's Code of Conduct. Failure to do so, may result in a BWB investigation being undertaken against the club with which the spectators are associated with. Sanctions against the club may be applied where appropriate.

SECTION 2 - BWB JUNIOR LEAGUE

SECTION 2.1 TEAM CRITERIA

2.1.1 All clubs registering to play in the Junior League must:

- (a)** have a minimum number of seven players per team
- (b)** have a Twitter handle (for their team, club or parent club)
- (c)** have a team or club Facebook Page
- (d)** have access to a venue for their hosted round that:
 - meets minimum national league requirements, including a one metre run off
 - has changing rooms that can be designated for male and female players/officials
 - has an appropriate number of accessible toilets

2.1.2 Players must play for the junior team of the team they are licenced with for National League if that team enters Junior League. Only where the National League team does not enter Junior League will players be able to play for another team.

2.1.3 All Team Managers and coaches must have attended one of Safeguarding and Protecting Children 1, Time to listen course or Sport Scotland Child Wellbeing and Protection in Sport by 31st January 2023. Failure to have done so will result in entry for that team being revoked by BWB.

2.1.4 All Junior League teams must have a licenced Level 2 coach in attendance at every fixture. If no licenced level 2 is available, the fixture will be postponed in accordance with regulation 8.14 and 8.15 found in the section above.

SECTION 2.2 COMPETITION FORMAT

2.2.1 Junior League will consist of pools of three or four teams. Each team hosts one round of three games, involving two opposition teams.

2.2.2 The number of pools is determined by the number of entrants.

2.2.3 Pool groups will be regionalised as best as possible to avoid long travel distances

2.2.4 Two points will be awarded for a win, one point will be awarded for a defeat

ELITE 8S

2.2.5 The top eight teams will qualify for the 'Elite 8's' which will be hosted by BWB at Wildcats Arena, Nottingham on Saturday 20th April 2024

2.2.6 *The Junior League final will be played at the National Championship Finals on 18th & 19th May 2024, University of Essex (CO4 3SQ)*

2.2.7 To play in the Junior League Elite 8s, players must have participated in a minimum of one pool round for their team. Exceptions to this will only be considered with the submission of medical evidence in writing to BWB, a minimum of 14 days before the Elite 8s.

2.2.8 All qualifying teams will be expected to attend the 'Elite 8's' tournament with an eligible team. Cost of travel and, if necessary, associated accommodation costs must be met by the qualifying teams for the 'Elite 8's' and National Championship Finals.

2.2.9 All teams finishing top in their Pools will automatically qualify for the Elite 8's.

2.2.10 Pool winners will be seeded based on win ratio against the second placed team in the Pool followed by points average.

2.2.11 The remaining qualifying positions will be determined by the results against the top team in each Pool. If win - loss ratios are the same with more than three second placed teams, points average in the games against the top team will be used to determine the qualifying teams.

2.2.12 Fixtures will be compiled:

Game 1 - 1st v 8th

Game 2 - 2nd v 7th

Game 3 - 3rd v 6th

Game 4 - 4th v 5th

The Semi – Finals will be as follows:

Winner of Game 1 v Winner of Game 4

Winner of Game 2 v Winner of Game 3

2.2.13 Should the Elite's be cancelled due to adverse weather or Government restrictions, every effort will be made to find alternative date & venue. If this is not possible, all fixtures will be void.

SECTION 2.3 ARRANGEMENT OF JUNIOR LEAGUE FIXTURES

2.3.1 BWB will create the Junior League fixture list for clubs to organise their fixtures for the coming season.

2.3.2 All clubs must return their confirmed fixtures to:

membership@britishwheelchairbasketball.co.uk including their home fixtures dates, venue and tip-times by 28th August 2022. Failure to provide fixtures by this date may result in officials not being appointed, and the fixtures being forfeit.

2.3.3 Clubs will be responsible for arranging and hosting one round each, which should be held on one of the weekends specified below. However, clubs unable to host on these weekends may apply to the League and Competitions Manager for exemption, which may only be granted if it does not affect other fixtures.

2.3.4 The host club, plus two opposition teams will each play two games at each round.

2.3.5 It is expected – to reduce time away from home for travelling teams – that the home team will play the first and last game of each day, with the two away teams playing each other in the middle game of the day. An example format is given below:

Game 1	Host vs Away 1
Game 2	Away 1 vs Away 2
Game 3	Host vs Away 2

2.3.6 Teams placed in the same Pool as Northern Ireland are expected to travel to Northern Ireland for their round of Junior League. No exceptions to this will be made.

2.3.7 Junior League Fixtures are schedule as follows:

3 TEAM POOLS:

1st Round (14th/15th October 2023), Hosted by Team 1:

1v2

2v3

1v3

2nd Round (18th/19th November 2023) Hosted by Team 2:

2v1

3v1

2v3

3rd Round (13th/14th January 2024) Hosted by Team 3:

3v1

1v2

3v2

4 TEAM POOLS:

1st Round (14th/15th October 2023), Hosted by Team 1:

1v2

1v3

2v3

2nd Round (18th/19th November 2023) Hosted by Team 2:

2v1

2v4

4v1

3rd Round (13th/14th January 2024) Hosted by Team 3:

3v1

3v4

1v4

4th Round (10th / 11th February 2023) Hosted by Team 4:

4v2

4v3

3v2

2.3.8 All Pool rounds of the competition must have been completed by 17th March 2024.

GENERAL FINES AND PENALTIES RELATING TO ARRANGEMENT OF JUNIOR LEAGUE FIXTURES:

(a) Any club due to be playing away at Northern Ireland who refuses to travel will be fined up to £1000.

SECTION 2.4. THE CLASSIFICATION AND CONSTITUTION OF PLAYERS AND TEAMS IN THE JUNIOR LEAGUE

2.4.1 All games in Junior League will be played to a maximum team player classification on court as follows:

16 Points

The number of classification team points allowed on court is capped as follows:

18 Points

Note: The above is the maximum number adding of points allowable for the five players on court at any time including concessions for female players.

2.4.2 When each classifiable female goes on court, 1.0 is added to the team classification total up to the 18-team point cap, including able bodied players.

2.4.3 Non-classifiable players are permitted to play in the Junior League. When a non-classifiable female player goes on court, 0.5 is added to the team classification total up to the 18 team point cap. Only one non-classifiable- player per team may be on court at any one time.

SECTION 2.5. JUNIOR LEAGUE GAME RULES

2.5.1 The League will be played on 10ft hoops.

2.5.2 The Molten B6G4500 (size 6) ball will be used in all U18 competitions.

2.5.3 Games will be played according to IWBF rules. (i.e 4 x 10 minute quarters, plus periods of 5 minutes overtime as needed). Team and player foul limits as per IWBF rules.

2.5.4 Teams are not permitted to use a full court press if winning by more than 20 points.

Clarification: *for the purposes of these rules, a full court press is where four or more players are seeking to prevent the opposition from advancing the ball over the midcourt line within 8 seconds. One or two players hustling the ball handler or picking back an offensive player is not considered a press.*

Referee's will however use their discretion in the interests of ensuring flow of the game such that players / coaches / teams are provided with an opportunity to develop (the latter being a fundamental part of Junior League).

Violation of this rule will lead to possession being given to the team being 'pressed' at the halfway line opposite the table with a reset shot clock to 24 seconds. Persistent violation of the pressing rules could be judged by the referees to be a coach technical (failing to control players).

2.5.5 There must be a minimum of 10 minutes warm-up before each game.

2.5.6 Visual 24 second clocks will be used if available.

SECTION 2.6. OFFICIALS

2.6.1 No referee will be appointed to, or should be asked by clubs to referee fixtures involving club players from the same region due to a conflict of interest.

SECTION 3 - BWB WOMEN'S PREMIER LEAGUE

SECTION 3.1. TEAM ROSTER

3.1.1 Each Women's Premier League team must nominate all Podium and Academy funded athletes and Elite International/Overseas Athletes and submit via the BWB Nominated Player form. These players are not permitted to play in other Women's League Divisions. This BWB Nominated Player Form can be found [here](#) and must be submitted to membership@britishwheelchairbasketball.co.uk by 17th September 2023.

Status categorised as in receipt of an APA or Governing Body Endorsement (VISA) at 17th September 2023.

3.1.2 No player can be signed to play for a team in the Women's Premier League after 31st January 2024.

3.1.3 Players from teams in Division One & Two of the Women's League are permitted to play up into teams within the Women's Premier League.

3.1.4 Non-nominated Women's Premier League players are permitted to play in the Women's League.

3.1.5 The maximum number of Podium and Academy funded athletes permitted per team is capped at four. GB athletes are elite GB Senior Squad Athletes as identified by BWB' as being athletes in receipt of UK Sport APA funding to support the national team Elite training and development.

3.1.6 The maximum number of non-British nationals permitted per team is capped at four and must comply with all BWB GBE regulations and visa requirements where applicable.

3.1.7 Section 4. Transfers does not apply to Women's Premier League and transfers are not permitted at any point within the Season.

PENALTIES AND FINES RELATING TO TEAM ROSTER

(a) Failure to submit the BWB Nominated Player form by 17th September will result in a fine of £100.

SECTION 3.2. COMPETITION FORMAT

3.2.1 The Women's Premier League will comprise of four teams.

3.2.2 Each team will play 'home' and 'away' fixtures against the other three teams in the Premier League three times.

3.2.3 At the end of the 'regular season' all four teams will advance to the end of season Play-offs which will take place at the National Championship Finals (18th & 19th May 2024, University of Essex (CO4 3SQ)). These play-offs will comprise of single fixture Semi-Finals, 3rd v 4th play-off and Final.

3.2.4 To play in the Women's Premier League Semi-Finals and Finals, players must have participated in a minimum of four regular season fixtures for their team. Exceptions to this will only be considered with the submission of medical evidence in writing to BWB, a minimum of 7 days before National Championship Finals.

3.2.5 If two or more teams have the same win-loss record of all games in the group, the game(s) between these two or more teams shall decide on the final league position. If the two or more teams have the same win-loss record of the games between them, further criteria will be applied in the following order:

- (a)** Higher game points difference of the games between them.
- (b)** Higher number of game points scored in the games between them.
- (c)** Higher game points difference of all games in the group.
- (d)** Higher number of game points scored in all games in the group.
- (e)** If still tied before all games have been played in the group, tied teams shall share the same ranking. If these criteria still cannot decide at the end of the group phase, a draw shall decide on the final classification.

3.2.6 There is no promotion or relegation from the Women's Premier League. New entrants will be subject to BWB approval in line with High Performance Partnership requirements.

3.2.7 The format of the Women's Premier League is subject to change at BWB's discretion.

SECTION 3.3 ARRANGEMENT OF WOMEN'S PREMIER LEAGUE FIXTURES

3.3.1 The 2022-23 Women's Premier League season must take place between Friday 24th November 2023 and **Sunday 5th May**

3.3.2 The provisional Women's Premier League fixtures are scheduled for the following weekends

25th/26th November 2023

2nd/3rd December 2023

9th/10th December 2023

20th/21st January 2024

27th/28th January 2024

10th/11th February 2024

17th/18th February 2024

24th/25th February 2024

9th/10th March 2024

16th/17th March 2024

23rd/24th March 2024

3.3.3 Where agreed in advance with BWB and the opposition, Women's Premier League fixtures are permitted to take place on the Friday nights.

3.3.4 Women's Premier games are only permitted to be played on the weekends of a Home Nation Programme (including Commonwealth Games preparation and Regional Academies) if the teams involved do not have any athletes participating in a Home Nations Programme. The dates of the Home Nations Programme are:

21st/22nd October 2023

16th/17th December 2023

13th/14th April 2024

3.3.5 Failure to attend a play-off game on the dates prescribed above will result in the team forfeiting the fixture 20-0 and fine of £500.

SECTION 3.4. THE CLASSIFICATION AND CONSTITUTION OF PLAYERS AND TEAMS IN WOMEN'S PREMIER LEAGUE

3.4.1 All games in the Women's Premier League will be played to a maximum team player classification on court as follows:

14.5 Points

3.4.2 There are no additional points added to the classification points for juniors within the Women's Premier League.

3.4.3 Non-classifiable players are permitted to play in the Women's Premier League. Only one non-classifiable player may be on court at any one time as a 5.0 classification.

SECTION 3.5. WOMEN'S PREMIER LEAGUE GAME RULES:

3.5.1 Games will be played in accordance with the current IWBF rules of Wheelchair Basketball subject to the following local competition rules.

3.5.2 The League will be played on 10ft hoops.

3.5.3 There will be a 20-minute warm-up period prior to every match.

3.5.4 The duration of games will consist of four quarters of 10 minutes, stopping clock.

3.5.5 There will be a 10-minute break at half time.

3.5.6 Visual 24 second clocks must be used.

3.5.7 The Molten BG4500 (size 6) composite basketball is the official game ball in the Women's Premier League

SECTION 3.6. OFFICIALS

3.6.1 Where possible, three qualified referees will be appointed by the BWB Referee Appointment's Officer for all official fixtures.

3.6.2 The home team is required to provide registered and appropriately licenced Table Officials. Competition requirements are listed in Appendix 9.

3.6.3 Women's Premier League Teams must have BWB licenced statisticians. Teams must provide live game statistics for all home fixtures. Game statistics must also be provided to opponents.

PENALTIES AND FINES RELATING TO OFFICIALS

- (a)** Failure to provide BWB licenced Table Officials as per Appendix 9 at a game will incur a fine of £50 per official per game.
- (b)** Failure to provide a statistician at a Women's Premier League home game will incur a fine of £200.

SECTION 3.7. UNIFORM, EQUIPMENT & VENUE

- 3.7.1** All Women's Premier League teams must comply with the uniform guidelines as outlined in Appendix 7.
- 3.7.2** The BWB logo must appear on the front of the playing shirt (see diagram in Appendix 7)
- 3.7.3** All teams in the Women's Premier League must email their kit designs for approval at least one month prior to their first game. High resolution images must be sent of both the front and back with dimensions to membership@britishwheelchairbasketball.co.uk.
- 3.7.4** All wheelchair frames should be in accordance with the **Official IWBF Wheelchair Basketball Rules**. (Regulation 3.1, Page 15)
- 3.7.5** All Women's Premier League teams must comply with the Wheelchair guidelines as outlined in Appendix 8.
- 3.7.8** All home games must comply with the venue requirements of the League Standards Matrix (Appendix 9)

PENALTIES AND FINES RELATING TO UNIFORM & EQUIPMENT.

- (a)** Failure to adhere to uniform guidelines outlined in Appendix 7 will result in a fine of £100 per occurrence.
- (b)** Failure to comply with wheelchair guidelines as outlined in Appendix 8 will result in a fine of £100 per user, per occurrence.
- (c)** Failure to comply with league standards matrix for Venue Requirements will result in a fine of £100 per occurrence.

SECTION 3.8. LIVE STREAMING & TICKETS

- 3.8.1** BWB owns the commercial and broadcast rights to the Women's Premier League
- 3.8.2** All Women's Premier League fixture Live Streams must meet the BWB minimum broadcast standards (provided as a separate document).
- 3.8.3** All Women's Premier League Games must be live streamed in HD via BWB's YouTube channel. Live stream must include Commentary and on-screen graphics of score, time and 24 second clock. Team fouls and time outs desirable. Commentary quality must meet broadcast standards.
- 3.8.4** Live stream must be made available to BWB for live broadcast via BWB's digital channels and identified (by BWB) media outlets/broadcasters. Live stream is not to be simultaneously broadcast through other channels unless instructed by BWB.

- 3.8.5** Where games are streamed by a national broadcast partner, sufficient access to home game venue must be allowed ahead of fixture, as well as compliance with broadcast partners venue and production standards.
- 3.8.6** All streamed/broadcast games must use the BWB Women's Premier League brand identity and be clearly branded as a BWB Women's Premier League game in line with BWB minimum broadcast standards.
- 3.8.7** Where games are broadcast, BWB must obtain a full floorplan of the field of play and examples of sponsorship that may require approval by broadcaster. BWB/Broadcaster's decision is final.
- 3.8.8** Due to broadcasting rights, no team / title sponsors will be accepted onto any televised graphic or BWB press material. For example, should a team be called 'Grantham and Co Liverpool Docklands' the team would be called 'Liverpool Docklands' on all televised graphics and BWB press material. No exception to this rule will be made.
- 3.8.9** The home team must provide ten complimentary tickets each to both the away team and BWB per fixture.

PENALTIES AND FINES RELATING TO LIVE STREAMING

- (a)** Failure to comply with Live Streaming regulations will result in a £250 fine per occurrence

SECTION 3.9. SPONSORSHIP

- 3.9.1** BWB owns the commercial and broadcast rights to the Women's Premier League.
- 3.9.2** The home team at all fixtures must display a minimum of eight BWB courtside boards (which will include two National Lottery Branded Boards) of uniform size and shape. It is the home team's responsibility to produce the courtside boards to BWB's artwork specification.
- 3.9.3** All visible sponsorship whereby logos will appear on shirts, courtside boards or any other public facing property relating to the team must be submitted to membership@britishwheelchairbasketball.co.uk for approval prior to contract signing.
- 3.9.4** Advertising for hard alcohol, tobacco and pharmaceutical products is prohibited.
- 3.9.5** Advertising for a brand of beer or wine is permitted.
- 3.9.6** Engagement or promotion with a sponsor whose activities could be considered, in the reasonable opinion of BWB, likely to bring the reputation of the sport into disrepute is prohibited

PENALTIES AND FINES RELATING TO SPONSORSHIP.

- (a) Failure of a home to display a minimum of eight courtside board of uniform size and shape will result in a fine of £100 per occurrence.
- (b) Failure of a team to submit visible sponsorship deals for review by British Wheelchair Basketball will result in a fine of £250.

SECTION 13.10. PERFORMANCE ANALYSIS

- 3.10.1** It is compulsory for all Women's Premier League teams to undertake performance analysis per fixture and transfer all files using NAC Sport software (or similar with the agreement of BWB) within seven days of the fixture date to BWB.

PENALTIES AND FINES RELATING TO PERFORMANCE ANALYSIS

- (a) Failure to analysis a Women's Premier League fixture and transfer files within three days of the fixture date will result in a fine of £100 per occasion.

SECTION 4 - BWB WOMEN'S LEAGUE

SECTION 4.1. TEAM ROSTER

- 4.1.1** Clubs who enter the Women's League must register a minimum of seven players for each team. Women's League teams will have until 16th October to ensure they have seven licenced players to comply.
- 4.1.2** Any Division 2 or 3 registered player may play for any other club in Division 1 or 2, unless their club has a team in the higher division, in which case the player can only play for this higher club team.
- 4.1.3** Any registered player may play a maximum of two teams.
- 4.1.4** Only 1 player per team who is aligned with a WPL team is allowed on court at any one time in Division 2 or lower.

SECTION 4.2. COMPETITION FORMAT

- 4.2.1** The administration and organisation of the Women's League will be undertaken by BWB. A game schedule for each round of matches during the season will be provided prior to the first round of Women's League.
- 4.2.2** The Women's League consists of a number of National Divisions determined by team entries each season, which are organised at a central venue on weekends allocated by BWB during the season. The size, number and format of each division will be determined by team entry each season.
- 4.2.3** Two points will be awarded for a win, one point will be awarded for a defeat.

DIVISION 1

- (a)** Division 1 will comprise between four and six teams.
- (b)** Clubs are restricted to only one team in the Division 1.
- (c)** BWB will confirm the fixture format of Division 1 once entries for the entire Women's League has been confirmed.
- (d)** The team finishing bottom of the division at the end of the season will be relegated.
- (e)** BWB may retain a team due to be relegated in this division if a number of teams from Division 2 are prohibited from accepting promotion due to a club already having a team in Division 1, or for any other reason as seen fit by BWB.
- (f)** To play in any end of season play-off fixture players must have participated in one round of regular season fixtures for their team.

DIVISION 2

- (a)** BWB will confirm the fixture format of Division 2 once entries for the entire Women's League has been confirmed. The results from Division 2 fixtures will determine the regular season Division 2 Champions.
- (b)** The team finishing top in the division will be promoted to Division 1 the following season.
- (c)** The teams finishing in the bottom two positions in the division will be relegated to Division 3 the following season
- (d)** BWB may retain a team or teams due to be relegated in this division. BWB's decision is final.

DIVISION 3

- (a)** BWB will confirm the fixture format of Division 3 (if applicable) once entries for the entire Women's League has been confirmed. The results from Division 3 fixtures will determine the regular season Division 2 Champions.
- (b)** The team finishing in the top two positions in the league will be promoted to Division 2 the following season.

SECTION 4.3. ARRANGEMENT OF WOMEN'S LEAGUE FIXTURES

4.3.1 The 2023-24 Women's League season will take place on the following weekends:

Round 1 – 4th & 5th November 2023

Venue: University of Worcester

Round 2 – 3rd & 4th February 2024

Venue: Loughborough University

Round 3 – 2nd & 3rd March 2024

Venue: Cardiff Met University

4.3.2 Should any round of Women's League be cancelled due to adverse weather or Government restrictions, every effort will be made to find an alternative date & venue. If this is not possible, all fixtures from the specific round will be void.

GENERAL PENALTIES AND FINES RELATING TO FIXTURES ARE AS FOLLOWS:

(a) Clubs who have a team in the Women's League who fail to attend - £100 fine

SECTION 4.4. THE CLASSIFICATION AND CONSTITUTION OF PLAYERS AND TEAMS IN WOMEN'S LEAGUE

4.4.1 All games in the Women's League will be played to a maximum team player classification on court as follows:

Division 1	-	15.5 Points
All other Divisions	-	16 Points

The number of classification team points allowed on court is capped as follows:

Division 1	-	16.5 Points
All other Divisions	-	18.0 Points

Note: The above is the maximum number adding of points allowable for the five players on court at any time including concessions for female junior players.

4.4.2 When each junior player goes on court, 1.0 is added to the team classification total up to the maximum team point cap, including able bodied players.

4.4.3 Non-classifiable players are permitted to play in Women's League. Only one non-classifiable player may be on court at any one time.

SECTION 4.5. GENERAL RULES FOR WOMEN'S LEAGUE

4.5.1 The League will be played on 10ft hoops.

4.5.2 The Molten B6G4500 composite basketball is the official game ball in the Women's League.

4.5.3 BWB will provide the game ball only, clubs should provide their own warm up balls for each round of competition.

4.5.4 BWB will confirm game times for all Divisions once entries have been received.

4.5.5 Visual 24 second clocks will be used if available in all divisions.

4.5.6 There will be two time-outs per team, per half.

4.5.7 If required, overtime periods will be four minutes in length.

4.5.8 The half-time interval will be a maximum of ten minutes.

4.5.9 Prior to each fixture, warm-up allocations will be a maximum of fifteen minutes.

SECTION 4.6. OFFICIALS

4.6.1 Clubs must bring a Level 2 qualified and BWB licenced Table Official to each round of Women's League.

4.6.2 Table Officials will be allocated games in the playing schedule by the competition organiser and circulated in advance.

4.6.3 In all Women's League games two qualified referees will be appointed by the BWB Referee Appointment's Officer.

GENERAL PENALTIES AND FINES RELATING TO OFFICIALS ARE AS FOLLOWS:

(a) Failure to provide qualified & licenced Table Official for all appointed games, £100 fine per official.

APPENDIX 1. LICENCE CARDS & AGE ELIGIBILITY

CATEGORY	BORN BETWEEN
Senior Players	31/08/2005 or earlier
Junior Players	1/09/2005 – 31/08/2009

CATEGORY	ELIGIBILITY
Senior	To be eligible to play in senior BWB competitions, a player must have reached the minimum age of fourteen.
Junior	To be eligible to play in a National BWB Competition a junior player must have reached the minimum age of fourteen.
Junior League Player	<p>The minimum age a player can be to enter the U18 Junior League is thirteen. A player must be thirteen or older on 31st August 2022 in order to be registered. Any player may register as soon as they reach the age of thirteen irrespective of where in the season that date falls. thirteen irrespective of where in the season that date falls.</p> <p>The maximum age a player can be to enter the U18 Junior League is seventeen. A player must be seventeen or younger on 31st August 2023 in order to be registered.</p>

APPENDIX 2. NATIONAL LEAGUE TRANSFER FORM

1. British Wheelchair Basketball (BWB) will supply the form on request to a team/club secretary or licenced player.
2. The new club will sign the BWB National League Transfer Form and relevant sections of the form, and the player will also sign the form indicating consent to transfer.
3. The signed form is then sent to the BWB Head Office at:
membership@britishwheelchairsbasketball.co.uk .
4. If the 'Release' section has not been completed, British Wheelchair Basketball will forward it to the releasing club.
5. The releasing club has seven calendar days from dispatch of the form by the BWB, to sign and return the completed form to the BWB. Failure to sign and return the form and/or failure to give proper evidence of refusal of transfer will result in the player being transferred irrespective of the lack of consent.
6. There will be a £15.00 transfer fee added to the individual's profile on the BWB Membership Portal.

Note: Registrations and Transfers cannot be dealt with over the telephone by British Wheelchair Basketball

Player's Name (in BLOCK CAPITALS)	
Licence Number	
New Club	
We hereby declare that we wish to sign the above-named player. Signed (Club Secretary/Chairman)	

Releasing clubs must return this form to the British Wheelchair Basketball Membership Office within 7 days of the above date. Failure to do so will result in the player being automatically transferred as per procedure for Internal Transfers as laid down in the National League Rules.

Player Release Certificate	
We (club holding player's registration)	
Hereby certify that (name of player requesting release)	
Is free/is not free (delete as appropriate) to transfer their National League Registration	
Reason(s) for non release if any [Evidence must be produced within 14 days of receipt.]	
Signed (Club Secretary or Chairman)	
Date	

APPENDIX 3. MID – SEASON FIXTURE CHANGE REQUEST FORM

To be valid this form must be completed in full and signed by both clubs. Once complete please return to membership@britishwheelchairbasketball.co.uk at least twenty-one days prior to the original fixture date

Team responsible for requesting fixture change (This is also the team responsible for £15 admin fee if requested with less than 14 days notice.)	
Reason for fixture change request:	
Home Team:	Away Team:
Division:	e.g. Division 1 North
Original Date:	Proposed Date:
Original Venue:	Proposed Venue:
Original Tip –time:	Proposed Tip- time:

Requesting Team Secretary Name:	
Requesting Team Secretary email address:	
Signed by:	

Accepting Team Secretary Name:	
Accepting Team Secretary email address:	
Signed by:	

Additional Information:

APPENDIX 4. INTERNATIONAL CLEARANCE REQUEST FORM

BWB Club 2022-23	
Name of player requiring clearance:	
Nationality of player requiring clearance:	
Date of Birth:	
Name of last registered team:	
Season last played:	
Country / Federation:	
Name and email for contact at previous club (if known)	
Does this player have an agent?	
Agents Name:	
Agents Nationality:	

By submitting this request, I acknowledge that the above is true to the best of my knowledge.

Please return this to membership@britishwheelchairbasketball.co.uk

APPENDIX 5. BWB FACILITIES STANDARDS

The following information are venue requirements for National League, Women's Premier League, Women's Participation League and Junior League. All teams should use a venue that as a minimum matches the requirements below for all Official BWB matches.

- The playing court shall be marked with 5cm lines, all of the same colour and drawn in white or other contrasting colour and clearly visible
- The height of the ceiling or the lowest obstruction above the field of play must be a minimum of 7 metres.
- Lighting should be uniform across the field of play and be a minimum of 500 lux.
- The temperature of the playing venue should be between 16 °C – 19 °C where possible.
- If these standards are not met, it is the duty of the Referees to assess the safety and appropriateness of the venue and inform BWB of the outcome of this assessment.

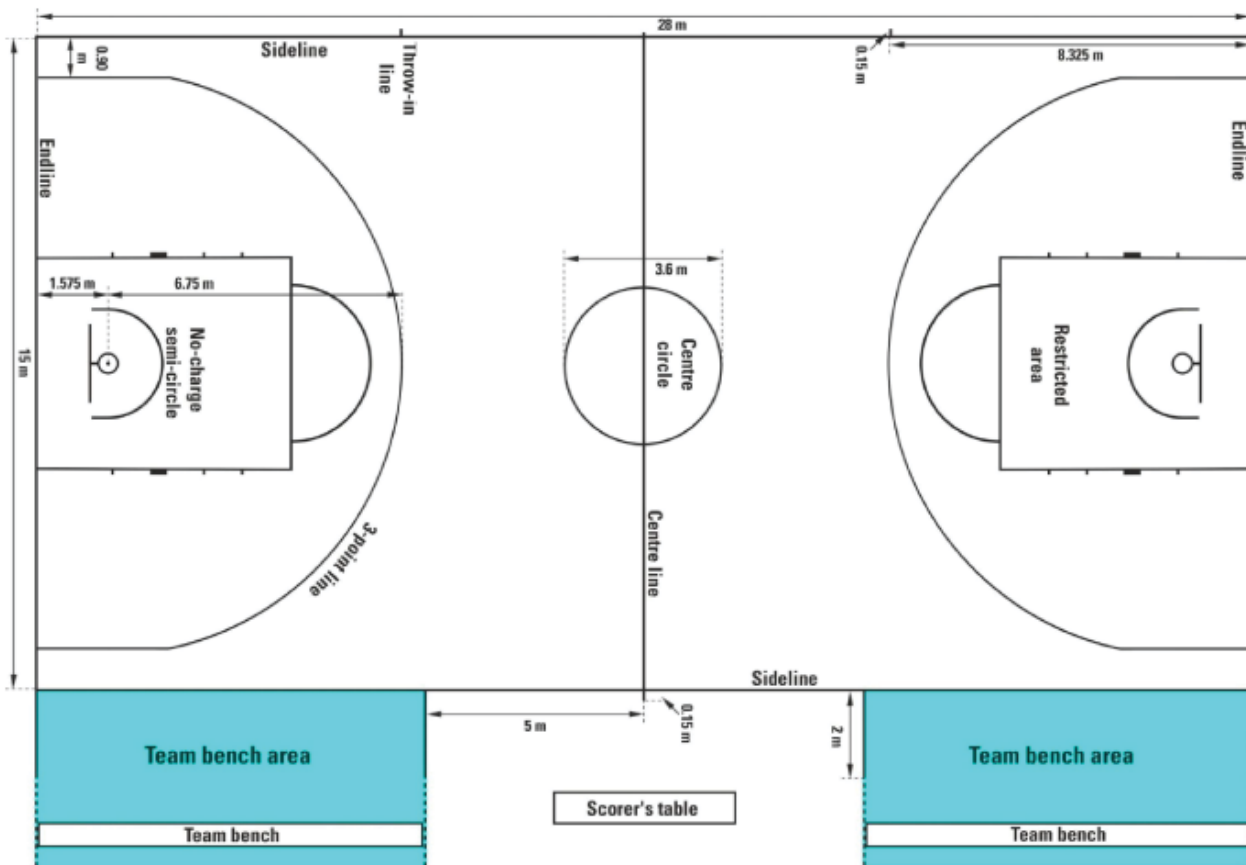

APPENDIX 6. RISK ASSESSMENT TEMPLATE

RISK ASSESSMENT FORM

Club:	Venue:	Assessor:

Hazard (What could cause harm?)	Risk (What could happen?)	Risk to (Who is affected?)	Existing Controls (What is done to minimise the risk?)	Risk Rating H - High M - Medium L - Low	Further Action Required
Inexperienced Staff / Volunteers and Stewards	Chain of command between BWB Staff & Officials / Arena staff and Volunteers not clear	Volunteers / Staff	<ul style="list-style-type: none"> Briefing meeting for senior volunteers Orientation for volunteers and link with senior volunteers Role Descriptions issued 	L	No further action required.
Safety in Car Parks and Arrivals / Drop Off	<p>Disabled athletes / supporters in Car Park areas.</p> <p>Pedestrians hit by moving vehicles. Car accidents.</p> <p>Coaches/vans/trailers on site – large vehicles</p>	Officials, Participants, Staff & Public	<ul style="list-style-type: none"> Site regularly operates events and deals with car parking issues. Clearly marked entrances and exits. Younger Athletes escorted by their parents / guardians / team staff. 	M	Venue Staff to support traffic management and deal with issues.
Injury from Competing / or during the event.					
Obstructions, wet floors, trailing cables, etc.					
Spectator or Player Aggression/Violence					
Spectator Seating					
Heat / Exhaustion					
Coronavirus Outbreak	Spread of Coronavirus	All			

**The above is an example and not an extensive risk assessment. Each club is required to produce their own risk assessment assessing all possible risk within their own environment.*

APPENDIX 7. UNIFORM GUIDELINES

(Mandatory only for Women's Premier League, guidelines for all other leagues and competitions)

SHIRTS

7.1 Advertising in line with BWB's sponsorship guidelines are permitted in line with dimensions outlined below:

- On the front of the shirts – max one main sponsor as indicated on diagram below, one additional sponsor is permitted but must not exceed the size of the club or BWB logo. Must not obscure player numbers
- On the back of the shirts – max two, must not obscure player numbers
- On the shorts/pants - Max one per leg

7.2 The front of the shirt shall conform to the following provisions:

- The manufacturer's trademark (logo) may appear, but it must not be larger than 12 cm².
- The BWB logo must appear on the front of the shirt. (only applicable to teams in the Women's Premier League)
- The player's number must appear and be clearly visible and at least 10 cm high. Any other markings on the front of the shirt must be at a distance of at least 5 cm from the player's number.
- The name or the badge or symbol of the club may appear on the front of the shirts as follows:
 - Above the advertising.
 - If the written text comprises one (1) line, the letters shall be a maximum of 8 cm in height. If the written text comprises two (2) lines, the letters on each line shall be a maximum of 6 cm in height.
 - The badge/symbol must not be smaller than 100 cm² nor larger than 200 cm² and shall be a maximum of 10 cm in height.

7.3 Advertising of one (1) sponsor only is permitted provided that the written text or the sponsor's logo is a maximum of 8 cm in height and maximum of 40 cm in length. One additional sponsor as identified in 7.1

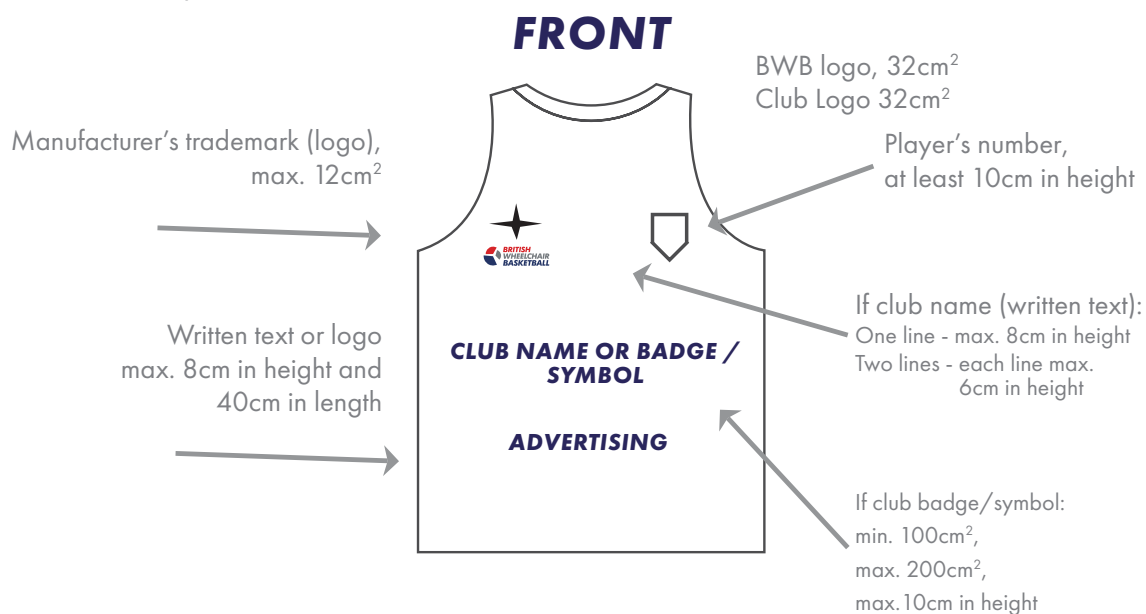

7.4 The back of the shirt shall conform to the following provisions:

- The player's surname may appear above the player's number and shall comprise only one (1) line of text. The height of the writing must be between 6cm and 8cm. If the player's surname is used on one shirt, the surnames of all players must appear on their shirts.
- The player's number must appear and be clearly visible and at least 20 cm high. Any other markings on the back of the shirt must be at a distance of at least 5 cm from the player's number
- Advertising of two sponsors only is permitted on the back of shirts, provided that the written text or the sponsor's combined logos are a maximum area of 400cm² and individually must not exceed a maximum of 8 cm in height and of 40 cm in length.



SHORTS/ TRACKSUIT TROUSERS

7.5 Advertising is permitted on the front of the shorts/pants (see diagram) provided that:

- o The advertising is of one sponsor only, and
- o The sponsor's written text or logo is of a maximum of 100 cm²
- o The manufacturer's trademark (logo) may appear, but it must not be larger than 12 cm².

7.6 The player's number is not permitted on the shorts/pants.

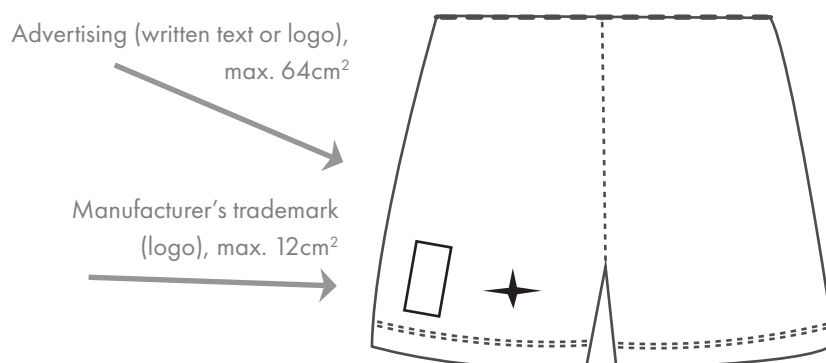

SOCKS

7.7 Advertising is prohibited on socks.

7.8 The manufacturer's trademark (logo) may appear, but it must not be larger than 12 cm².

WARM-UP T-SHIRTS

7.9 Advertising is permitted on the front of warm-up T-shirts but must be identical (same sponsor and size) with that on the front of the playing shirts.

7.10 The name or the badge/symbol of the club may appear on the front of the warm-up T-shirts.

7.11 Advertising is permitted on the back of warm-up T-shirts, but it must be identical (same sponsor and size) with that on the front of the shirt.

7.12 The manufacturer's trademark (logo) may appear, but it must not be larger than 12 cm².

TRACKSUITS

7.13 Advertising is permitted on the front of tracksuits but must be identical (same sponsor and size) with that on the front of the playing shirts.

7.14 The name or the badge/symbol of the club or country may appear on the front of the tracksuits.

7.15 Advertising is permitted on the back of tracksuits, but it must be identical (same sponsor and size) with that on the front of the shirts.

7.16 The manufacturer's trademark (logo) may appear, but it must not be larger than 12 cm².

7.17 The player's family name is permitted on the back of the tracksuit but it must be identical (same name and size) with that on the back of the shirts.

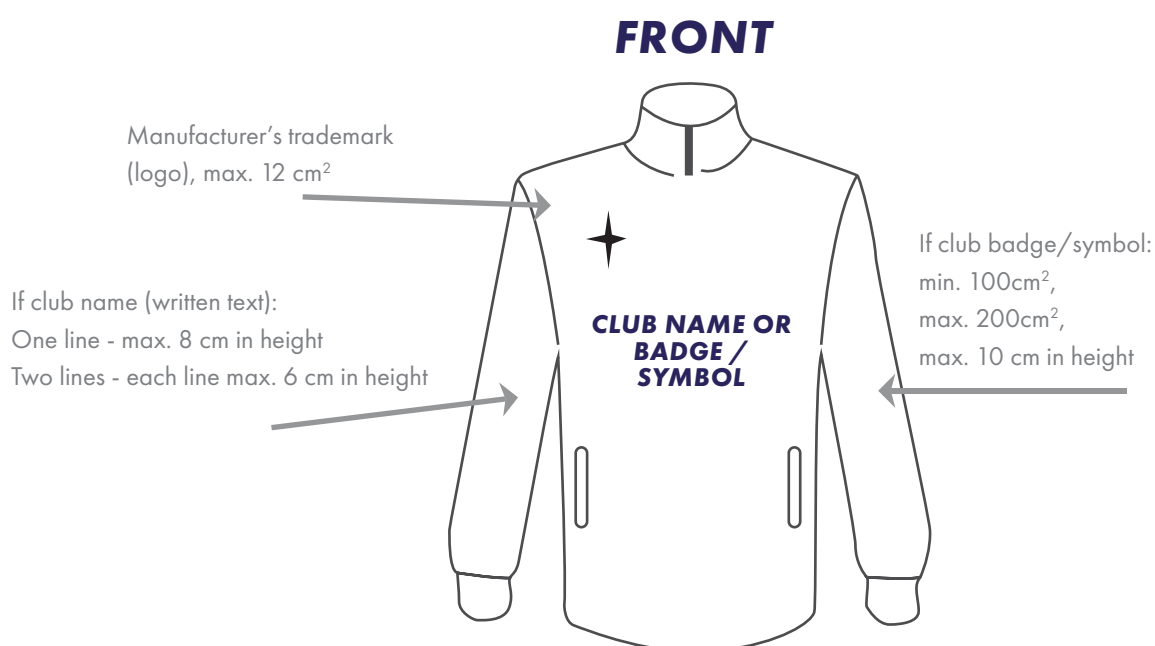



SHOES

- 7.18** Advertising is prohibited on the shoes.
- 7.19** The manufacturer's trademark (logo) may appear.

UNDERGARMENTS

- 7.20** All undergarments such as T-shirts worn under uniforms, cycling shorts, etc., must be the same colour as the respective part of uniform.
- 7.21** Advertising is prohibited on all visible parts of undergarments.
- 7.22** The manufacturer's trademark (logo) is permitted, but it must not be larger than 12 cm².

OTHER ACCESSORIES & PROVISIONS

- 7.23** Advertising is prohibited on all other accessories such as sweatbands, knee and elbow pads, etc.
- 7.24** The manufacturer's trademark (logo) is permitted, but it must not be larger than 12 cm².
- 7.25** Advertising on uniforms, tracksuits, and warm-up T-shirts must be the same for all players of a team.
- 7.26** The manufacturer's trademark (logo) on uniforms, tracksuits, and warm-up T-shirts must be the same for all players of a team.
- 7.27** Advertising for hard alcohol, tobacco and pharmaceutical products are prohibited.
- 7.28** Advertising for a brand of beer or wine is permitted.

BWB LOGO

7.29 BWB Logo can only be featured in white (reverse out) or full colour

7.30 Brand colours must be pantone matched on full colour version

7.31 White logo to be used on darker kit colours

7.32 Full colour logo on lighter kit colours

7.33 No other colour variation of BWB logo allowed

7.34 BWB logo must always feature at 80mm in width

7.35 BWB logo proportions must not be distorted or font's changed.

7.36 Full logo can only be used, and no deconstructed version is allowed.

APPENDIX 8. WHEELCHAIRS

8.1 Advertising is prohibited on the wheelchair frame, frame protectors and side guards.

8.2 The manufacturer's logo may appear in a maximum of two places on the frame tubing or frame protectors and may not exceed 2 cm in height and 20 cm in length

8.3 Advertising is prohibited on the cushion.

8.4 The manufacturer's logo may appear on the side or both sides of the cushion but must not exceed 30 cm² in each instance.

8.5 Advertising is prohibited on the back upholstery.

8.6 The manufacturer's logo may appear on the back upholstery but must not exceed 30 cm².

8.7 Advertising is permitted on the player numbers attached to the back upholstery provided that:

- o the player number is clearly visible,
- o the writing or the sponsor's logo is a maximum of 25% of the surface area,
- o it is identical to the one on the front of the shirt.

8.8 Advertising is prohibited on the wheels.

8.9 The manufacturer's logo may appear on the wheels but must not exceed 12 cm².

8.10 Players may choose whether to use spoke protectors or not. Colourless, transparent spoke protectors where no printing appears are considered, for advertising purposes, to be in the same category as wheels that do not possess spoke protectors.

8.11 When spoke protectors are used, other than the colourless, transparent type, they must be of identical design and colour for all players on a team that decide to use them.

8.12 Advertising is permitted on spoke protectors and is the only location on the player's uniform/wheelchair where a second sponsor may be positioned in addition to the first sponsor that is permitted in other locations detailed in these regulations. Need to add size limit for ad and clean up how this is said. Figure out size based on 25% ratio.

8.13 The manufacturer's logo of the specific wheelchair in question may appear on both spoke protectors but must not exceed 12 cm² in either instance.

APPENDIX 9. 2023-24 LEAGUE STANDARDS MATRIX

2023-24 Season	2023-24 Season	National League				Women's Competitions			U18's
		Premier League	Division 1	Division 2	Division 3	Premier League	Women's League Division 1	Division 2	Junior League
People	First Aider (Host)	C	C	C	C	C	C	N/A	C
	Safeguarding Training (Welfare Officer)	C	C	C	C	C	C	C	C
	Coach Qualifications	Level 3 = D Level 2 = C	Level 3 = D Level 2 = C	Level 2 = C	Level 2 = C	Level 3 = C Level 2 = C	Level 3 = C Level 2 = C	Level 2 = C	Level 3 = C Level 2 = C
	Coach Requirements	DBS = C Safeguarding = C Coach Clean = C	DBS = C Safeguarding = C Coach Clean = C	DBS = C Safeguarding = C Coach Clean = C	DBS = C Safeguarding = C Coach Clean = C	DBS = C Safeguarding = C Coach Clean = C	DBS = C Safeguarding = C Coach Clean = C	DBS = C Safeguarding = C Coach Clean = C	DBS = C Safeguarding = C Coach Clean = C
	Table Officials	Level 3 x 1 = C Level 2 x 2 = C	Level 3 = D Level 2 = C Level 1 = C	Level 2 = C Level 1 = C	Level 2 = C Level 1 = C	Level 3 x 1 = C Level 2 x 2 = C	Level 3 x 1 = D Level 2 x 1 = C Level 1 x 1 = C	Level 2 = C Level 1 = C	Level 3 = D Level 2 = C Level 1 = C
	Welfare Officer	C	C	C	C	C	C	C	C
	Statisticians	C	D	D	N/A	C	N/A	N/A	C
	Fiba Live Stats	C	C	C	D	C	C	C	C
Venue	Timber A3 or A4 Floor (or similar if agreed by BWB)	C	C	C	C	C	C	D	C
	Backboard & Ring (European Standard EN 1270 with white net, timber or transparent backboard)	C	C	D	D	C	C	C	C
	Minimum Court Size	C	C	C	C	C	C	C	C
	Fiba Court Markings (post London 2012)	C	D	D	D	C	C	C	D
	Wall Mounted Scoreboard	C	C	D	D	C	C	C	C
	24 Second Clock	C	C	D	D	C	C	D	D
	Minimum Run Off (endlines)	2m	2m	2m	2m	2m	2m	2m	2m
	Minimum Run Off (sidelines)	2m	2m	1m	1m	2m	1m	1m	1m
	Temperature	16-19°C	16-19°C	16-19°	16-19°	16-19°C	16-19°	16-19°	16-19°
Game Ball	B7G4500	B7G4500	B7G4500	B7G4500	B6G4500	B6G4500	B6G4500	B6G4500	

C=Compulsory

D = Desirable

New this season

KEY:

** Recognised Safeguarding and Protecting Children Courses

We recommend that you attend face-to-face safeguarding training every 3 years.

Face-to-face training

UK Coaching Safeguarding and Protecting Children NSPCC Time to Listen Training

Sport Scotland Child Wellbeing and Protection in Sport

Courses outside of the list must be submitted to BWB and will be reviewed on their learning outcomes, duration and course content.



BRITISHWHEELCHAIRBASKETBALL.CO.UK

British Wheelchair Basketball
SportPark
3 Oakwood Drive
Loughborough
LE11 3QF
Tel: 01509 279900
Email: office@britishwheelchairbasketball.co.uk